

# Commander 3400

24V System – Units #535 and above

# User Manual



# MPS-3400 Series

Revision 8.2 – Units #535 and above

## Contents

1. Introduction.....	4
2. Safety Notes.....	5
2.1. Operating Notes .....	5
2.2. Service Safety .....	6
2.3. Towing Safety.....	7
2.4. Moving Trailer Safety.....	7
2.5. Reporting Trailer Safety Defects.....	8
2.6. Unit VIN / Serial Number Locations .....	8
2.7. Safety Symbol Summary .....	9
3. Specifications .....	10
4. General Operations .....	11
4.1. Mounting Components .....	11
4.2. Power Control Module.....	12
4.3. Powering up the Trailer .....	18
4.4. Communications.....	19
4.5. Shore (Land) Power – Operation/Battery Charging .....	19
4.6. Powering Down .....	19
4.7. Automatic Low-Voltage Battery Detection.....	20
5. Generator Operations.....	21
5.1. Powering on the Generator (Auto).....	21
5.2. Powering on the Generator from the PCM (Manual).....	21
5.3. General Operation.....	21
5.4. Fueling .....	22
5.5. Manual Starting and Maintenance .....	22
6. Power Control Module Operations.....	23
6.1. Enclosure Temp .....	23
6.2. Generator Status .....	23
7. Rack-Mount Module .....	23
7.1. AC power control and outlet power strip .....	24
7.2. Hardware Drawers and Mounting System .....	24

8. Trailer Deployment .....	24
8.1. Daily Inspection .....	24
8.2. Towing the Trailer.....	25
8.3. Leveling the Trailer.....	25
8.4. Mounting Components .....	27
8.5. Raising the Mast.....	27
8.6. Lowering the Mast.....	28
9. Preventive Maintenance Schedule .....	29
9.1. Jack Maintenance .....	29
9.2. Winch Maintenance.....	30
9.3. Battery Operation & Maintenance.....	31
10. Connector Locations and Wiring Diagrams .....	33
10.1. External Connector Locations.....	33
10.2. Power Control Module.....	35
10.3. Body Pinouts on the Power Control Module .....	36
10.4. Rack Board .....	37
10.5. Enclosure Lights Diagram.....	39
10.6. Trailer Extension Cable and Production Wiring.....	40
10.7. Winch Limit Switches.....	41
10.8. Winch Control Wiring.....	42
Appendix A – Cameras and Accessories.....	43
I. Mounting Positions .....	43
II. Accessories.....	44
III. IP Cameras .....	47
IV. ExacqVision Video Management Software .....	47
V. Network and Cellular Devices.....	47
Appendix B – Generators .....	47
Fueling.....	47
Cummins Onan 4000 KY .....	48
Power Tech PT-3SV2 .....	49
Appendix C – Solar Options .....	51
600W Solar 2 Panel System .....	51
900W Solar 3 Panel System .....	52

# 1. INTRODUCTION



**This manual describes the standard MPS-3400 series Mobile Surveillance Trailer. See appendices for customized configurations. Due to customization, never assume the information is for your configuration.**

**Check for your production version in the appendices before you operate this product!**

This manual provides information and procedures to safely operate and maintain the Mobile Pro Systems Mobile Surveillance Trailer.

For your own safety – and protection from physical injury – carefully read, understand and observe the safety instructions described in this manual. *The information contained in this manual is based on machines in production at the time of publication. Mobile Pro Systems reserves the right to change any portion of this information without notice.*

DO NOT MODIFY or use this equipment for any application other than which it was designed.

Mobile Pro Systems recommends that a trained and licensed professional perform all electrical wiring and testing functions. Any wiring should be in compliance with the United States National Electric Code (NEC), state and local codes and Occupational Safety and Health Association (OSHA) guidelines.

Keep a copy of this manual with the unit at all times. Additional copies and updated copies are available from Mobile Pro Systems.

For units with a Gas-powered or Diesel-powered generator, see specific appendices for your products from Mobile Pro Systems.

**For technical or parts QUESTIONS, please contact Mobile Pro Systems Customer Support or Technical Support team at 651-434-2333. Please have your system serial number available during the call.**

**To ORDER SERVICE PARTS, please contact the dealer from which you purchased the unit or call Mobile Pro Systems directly to locate a dealer in your area.**

## 2. SAFETY NOTES



This is the safety alert symbol. It is used to alert you to potential personal injury hazards. Obey all safety messages that follow this symbol to avoid possible injury or death.

This manual contains **DANGERS, WARNINGS, CAUTIONS, NOTICES** and **NOTES** which must be followed to prevent the possibility of improper service, damage to the equipment, personal injury or death.

The following formatting options will apply when calling the reader's attention to the **DANGERS, WARNINGS, CAUTIONS, NOTICES** and **NOTES**.

### **DANGER**

**INDICATES A HAZARDOUS SITUATION WHICH, IF NOT AVOIDED, WILL RESULT IN DEATH OR SERIOUS INJURY.**

### **WARNING**

**Indicates a hazardous situation which, if not avoided, could result in death or serious injury.**

### **CAUTION**

Indicates a hazardous situation which, if not avoided, may result in minor or moderate injury.

Indicates a hazardous situation which, if not avoided, may result in property or equipment damage.

#### **Note**

*Notes contain additional information important to a procedure and will be found within the regular text body of this manual.*

## 2.1. OPERATING NOTES

Before using the Mobile Surveillance Trailer, be sure you read and understand all the instructions. This equipment was designed for specific applications; **DO NOT** modify or use this equipment for any application other than which it was designed. Equipment operated improperly or by untrained personnel can be dangerous!

Read the operating instructions and familiarize yourself with the location and proper use of all instruments and controls. Inexperienced operators should receive instruction from someone familiar with the equipment before being allowed to operate or set up the Mobile Surveillance Trailer. The following points should always be practiced:

- The area immediately surrounding the camera mast should be dry, clean, and free of debris.
- Position and operate the Mobile Surveillance Trailer on a firm, level surface.
- **NEVER** operate a unit in need of repair.
- Lower mast when not in use, or if high winds or electrical storms are expected in the area.
- Make certain the Mobile Surveillance Trailer is well grounded and securely fastened to a good earthen ground.

- The tower extends up to 36 feet (11m). Make sure area above trailer is open and clear of overhead wires and obstructions.
- **Keep area behind trailer clear of people while raising and lowering mast!**
- Keep all body parts and other loose items clear of winch and cable during operation and while in tension.
- **NEVER** raise, lower or turn mast while unit is operating!
- **NEVER** move the trailer while the mast is up.
- **NEVER** deploy the trailer on substantially uneven ground.
- **Trailer must be leveled, and outriggers (jacks) extended before raising mast.** Outriggers must remain extended to the first latch point while mast is up.
- **IMPORTANT:** The outriggers are only designed to stabilize the trailer. The most effective positioning of the outriggers is on the first latching point, about 18" out. The outrigger system is not designed to lift the trailer, especially on unlevel ground.
- If for any reason any part of the mast hangs up or winch cable develops slack while raising or lowering mast, **STOP immediately!** Contact an authorized service representative.
- **NEVER** remove pull mast locking pin while tower is up!
- **NEVER** use tower if insulation on electrical cord is cut or worn through.
- **NEVER** operate a unit while tired, distracted, or under the influence of drugs or alcohol.

## 2.2. SERVICE SAFETY

This unit uses high voltage circuits capable of causing serious injury or death. Only a qualified electrician should troubleshoot or repair electrical problems occurring in this equipment.

- Before servicing the camera mast, make sure the high voltage portions are turned to OFF by unplugging the 120 Volt AC power cord and disabling the generator from running, circuit breakers are open (off) and the battery banks are disconnected. **NEVER** perform even routine service unless all electrical components are shut down.
- **NEVER** allow water / ice to accumulate around the base of the mast system. If water is present, **DO NOT** service!
- **NEVER** service electrical components if clothing or skin is wet. If the unit is stored outside, check the components and trailer housing for any moisture and dry the unit before use.
- **NEVER** wash the unit with a power washer or high-pressure hose. Water could splash into the electronics.
- Open main circuit breakers before disconnecting battery cables.
- Keep hands, feet, and loose clothing away from moving parts of the system.
- Wear heavy leather gloves when handling winch cables. Never let cables slip through bare hands.

- Make sure slings, chains, hooks, ramps, jacks, and other types of lifting devices are attached securely and have enough weight-bearing capacity to lift or hold the equipment safely. Always remain aware of the position of other people around you when lifting the equipment.
- **NEVER** allow anyone under the trailer while the trailer is being lifted off the ground.

## 2.3. TOWING SAFETY

Towing a trailer requires care! Both the trailer and vehicle must be in good condition and securely fastened to each other to reduce the possibility of an accident. Also, some states require that trailers be registered and licensed. Contact your local Department of Transportation office to check on license requirements for your specific unit. This unit could be classified as a “special use trailer vehicle” in many states and does not require a license. Contact your local Department of Transportation for clarity of licensing.

- Check that the hitch and coupling on the towing vehicle are rated equal to, or greater than, the trailer's “gross vehicle weight rating” (GVWR).
- Check tires on trailer for tread wear, inflation, and condition.
- **DO NOT** tow trailer using defective parts! Inspect the hitch and coupling for wear or damage.
- Make sure the trailer hitch and the coupling are compatible. Make sure the coupling is securely fastened to the vehicle.
- Connect safety chains in a crossing pattern under the tongue and attach the breakaway cable **TO THE REAR BUMPER OF THE TOWING VEHICLE**. Do not attach the cable to the trailer hitch.
- Make sure directional and brake lights on the trailer are connected and working properly.
- Check that all lug nuts holding wheels on are tight and that none are missing.
- Maximum recommended speed for highway towing is 55 mph. Recommended off-road towing speed is not to exceed 10 mph or less depending on terrain.
- When towing, maintain extra space between vehicles and avoid soft shoulders, curbs and sudden lane changes. If you have not pulled a trailer before, practice turning, stopping, and backing up in an area away from heavy traffic.
- A film of grease on the coupler will extend coupler life and eliminate squeaking. Wipe the coupler clean and apply fresh grease each time the trailer is towed.
- **NEVER tow the system if the solar panels are NOT locked down!**
- **NEVER tow the system if the mast is NOT down and fully fastened into place!**

## 2.4. MOVING TRAILER SAFETY

- Only move trailer with a quality trailer hand cart rated for at least 600 lbs. trailer tongue weight.
- Hand carts should only be used on totally flat surfaces.
- Never move the trailer on an uneven surface. It is not designed to withstand sand, gravel, pavement cracks, snow, ice, or any other uneven surface.

- The front wheel jack is intended for small movements to position the trailer while attaching the hitch.
- The front wheel jack IS NOT intended to be used in place of a trailer hand cart.
- The front wheel jack WILL NOT support the weight of a vertical mast.
- Never allow the mast in the vertical position and move the trailer for any reason.
- Never move the trailer where the ground is not totally flat.
- Generally, to avoid damage to the trailer or personally injury, the trailer should only be moved while attached to a tow vehicle of sufficient size.

## 2.5. REPORTING TRAILER SAFETY DEFECTS

If you believe your trailer has a defect which could cause a crash or could cause injury or death, you should **immediately stop the use of the system and inform Mobile Pro Systems.**

## 2.6. UNIT VIN / SERIAL NUMBER LOCATIONS

Refer to the illustrated locations to find the VIN tag. Important information, such as the model number and Vehicle Identification Number (V.I.N.) for your trailer are found on these tags. Record the information from these tags, so it is available if the tags are lost or damaged.

When ordering parts or requesting technical service assistance, you may be asked to specify this information.

The VIN ID tag identifies the:

MANUFACTURED BY/FABRIQUE PAR:

GVWR/PNBV:

DATE OF MFG:

COLD INFL. PRESS. /PRESS.

DE GONF A FROID

GAWR/PNBE TIRE/PNEU RIM/JANTE KPA (PSI/LPC) SGL/DUAL

THIS VEHICLE CONFORMS TO ALL APPLICABLE STANDARDS PRESCRIBED UNDER THE US MOTOR VEHICLE SAFETY REGULATIONS

IN EFFECT ON THE DATE OF MANUFACTURE/ CE VEHICULE EST CONFORME A TOUTES LES NORMES QUI LUI SONT APPLICABLES EN VERTU DU REGLEMENT SUR LA VEHICULES DES AUTOMOBILES DU CANADA EN VIGUEUR A LA DATE SA FABRICATION. THIS VEHICLE CONFORMS TO ALL APPLICABLE U.S. FEDERAL MOTOR VEHICLE SAFETY STANDARDS (FMVSS) IN EFFECT ON THE DATE OF MANUFACTURE SHOWN ABOVE. V.I.N. /N.I.V.: TYPE/TYPER DE VEHICULE:

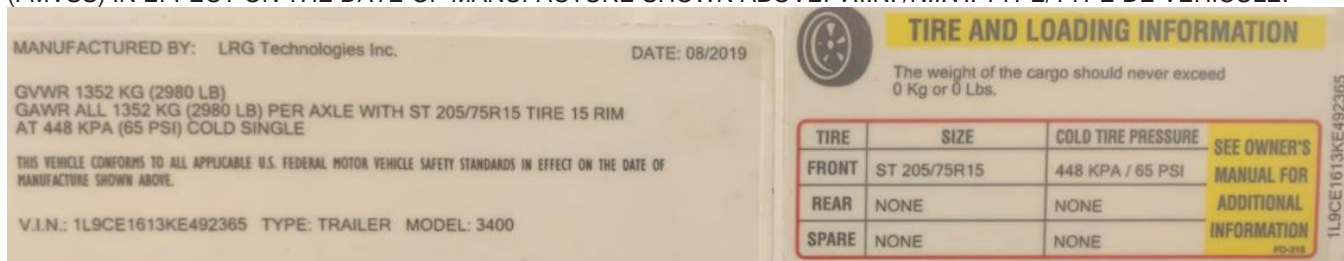

The ID tags are located near the wheel well.

This ID tag identifies the:

System Model Number:

System Serial Number: (same as the fabrication tag)

## 2.7. SAFETY SYMBOL SUMMARY

This equipment has been supplied with numerous safety and operating decals. These decals provide important operating instructions and warn of dangers and hazards. Replace any missing or hard-to-read decals and use care when washing or cleaning the unit. For decal replacement please call Mobile Pro Systems at 651-434-

Below is a summary of the intended meanings for the symbols used on the decals.



Safety alert symbol; Used to alert you to potential personal injury hazards.



Read and understand the supplied operator's manual before operating unit.



Unit electrical ground.



Anchor/tie down point.



Forklift here only.



Lift here only.



Asphyxiation hazard; Operate in well-ventilated area.



Dangerous voltage may be present.



Crush hazard: Keep body parts clear of this area.

### 3. SPECIFICATIONS

Read this manual carefully before attempting to use this Mobile Surveillance Trailer. The potential for property damage, personal injury or death exists if this equipment is misused or installed incorrectly. Read all manuals included with this unit. Each manual provides detailed information regarding items such as set-up, use, and service requirements.

SPECIFICATIONS ARE SUBJECT TO CHANGE WITHOUT NOTICE.

#### Mobile Pro Systems MODEL MPS-3400

Make/Brand .....	Mobile Pro Systems
Model .....	MPS-3400
Battery Type – Group Number .....	Series 31 AGM
Battery Voltage (Quantity per Unit) .....	12-12v batteries main bank in a 24v configuration
Battery Rating .....	100 amp-hours each
Battery Quantity .....	13- includes one Generator and Mast control battery

#### Weights

Dry Weight lbs (kg) .....	2789 (1265) (Shell)
Operating Weight lbs (kg) .....	2980 (1351) (Fueled)

#### Dimensions

Length w/ mast stowed inches (m) .....	194 (4.93)
Width inches (m) .....	64 (1.63)
Width w/ outriggers extended inches (m) .....	98 (2.49)
Height w/ mast stowed inches (m) .....	72 (1.83)
Maximum height of mast ft (m) .....	36 (10.97)

#### Trailer

Number of Axles .....	1
Capacity - Axle Rating lbs (kg) .....	3500 (1588)
Tire Size – inches .....	15
Tire Load Rating .....	D
Hitch, standard .....	2" Ball
Maximum Tire Pressure – psi .....	65 cold

## 4. GENERAL OPERATIONS

### 4.1. MOUNTING COMPONENTS

Upon delivery of your new MPS-3400, please take a minute to verify that you have received all devices and components (refer to Appendix A, Section II for details on the devices and components included in your Mobile Surveillance Trailer).

1. After all devices and components are accounted for, begin by mounting the cameras to the corresponding positions on the mast. See Appendix A, Section I for diagrams of the specific mounting positions or a similar layout for your trailer.
2. Screw the camera mount onto the mounting rod on the mast cross bar. Rotate the camera so the ethernet port on the camera mount is facing inward toward the top mast enclosure.
3. Secure the camera by spinning the jam nut on the mast cross bar mounting bolt towards the camera mount to create a snug fit.
4. Attach the provided ethernet patch cords from the camera mount to the mast control box. Each camera is labeled with a CAM #. Match the number with the same number patch cable and connect to the top mast box.
5. For trailers that include a laptop computer system, place the laptop in the bottom drawer of the removable rack-mount enclosure.

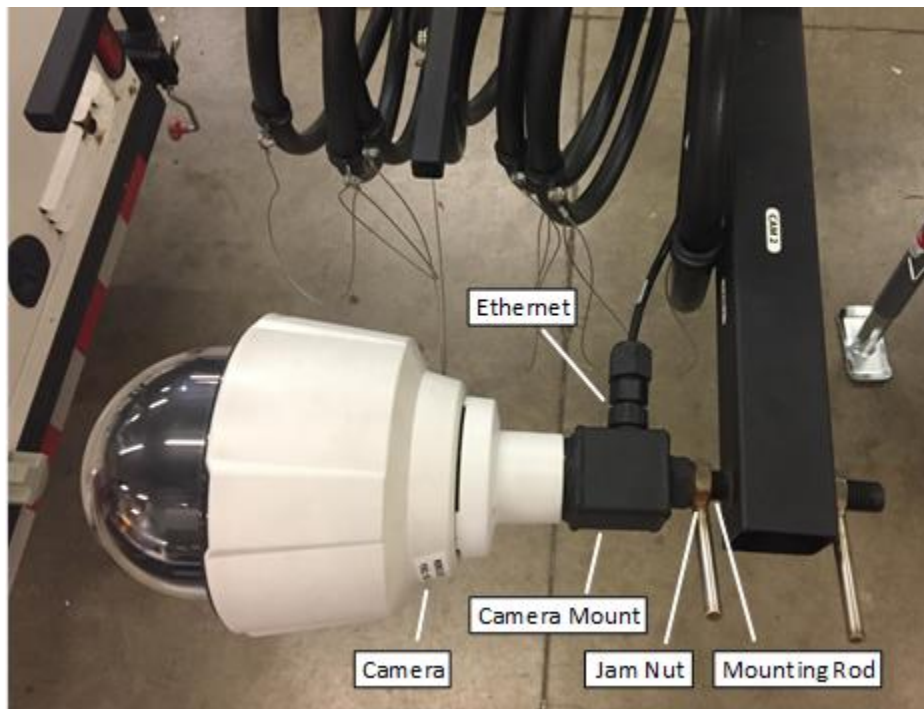

For operation of your specific devices, refer to Appendix A, Sections III – V.

## 4.2. POWER CONTROL MODULE

Before operating the system, please read and follow the Introduction and Safety Notes. Always place the trailer on firm, flat ground before operating, and be sure the area behind and above the trailer is clear. Always check for adequate fuel levels.

Since each MPS-3400 may have specific customizations, operation will not always be the same for each unit. Look for specific operating instructions for your MPS-3400 from your local provider.

The PCM (Power Control Module) manages the power system operations such as battery charging, automatic generator startup and shutdown, low-voltage detection and mitigation, short-circuit protection, power control of external devices, solar panel power, and other power management functions. This system is controlled in the PCM with a microprocessor which manages these functions automatically. However, if the trailer has a network connection to the internet, it also sends the operating telemetry data through the internet to a web portal hosted which allows the trailer operator to login and see the current electrical characteristics real-time as the trailer is operating. Although the PCM automatically controls the operation of most devices in the trailer, many of these functions can have the automatic operation overridden and controlled manually through the web portal interface for diagnostic purposes or specialized operations.

## Power Control Module (PCM) Controls Layout

The PCM shown to the left has the following sections from top to bottom:

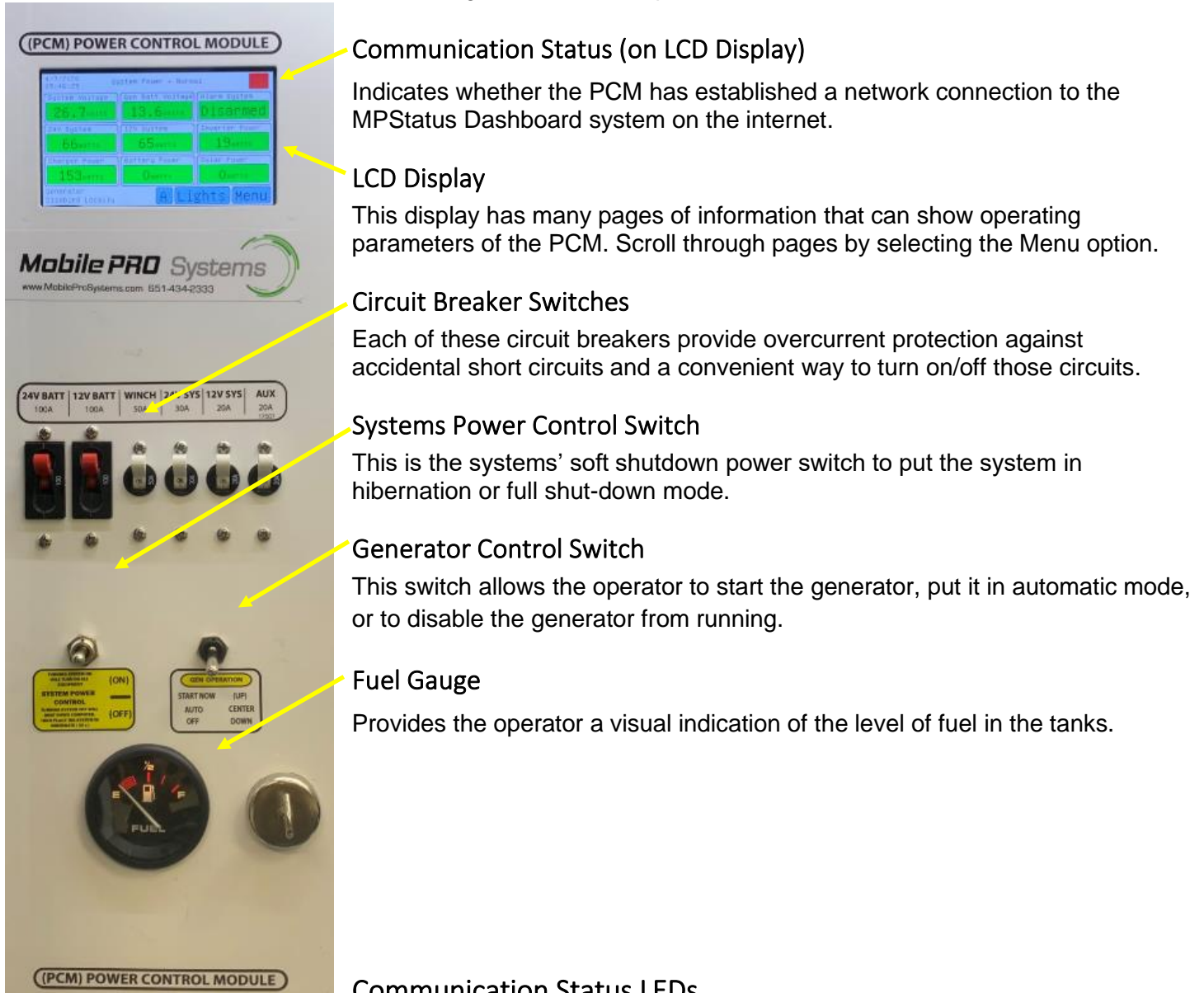

Indicates whether the PCM has established a network connection to the MPStatus Dashboard system on the internet so that it can successfully transmit operational telemetry data. The green LCD indicator when lit signals that a network connection has been established. When the green LCD is lit, the yellow indicator blinks when data is being transmitted to/from the MPStatus Dashboard on the internet cloud. If the green LCD is not lit, the yellow indicator will occasionally blink with a very short pulse about every five seconds which shows that it is attempting to establish a new connection to the MPStatus Dashboard on the internet using the TCP networking protocol on port 2000 or secure port 4120.

### LCD Display

This display has many pages of information that can show operating parameters of the PCM. The Page Up and Page Down buttons will allow the operator to scroll up or down through the pages of information. When these buttons are untouched for five minutes, the LCD display will return to the home page which shows the battery voltages and currents. The LCD Display has the following pages of information. However, not all trailers

will necessarily have all the possible pages, or screen content may slightly differ depending on model and what optional equipment may or may not be installed in the trailer.

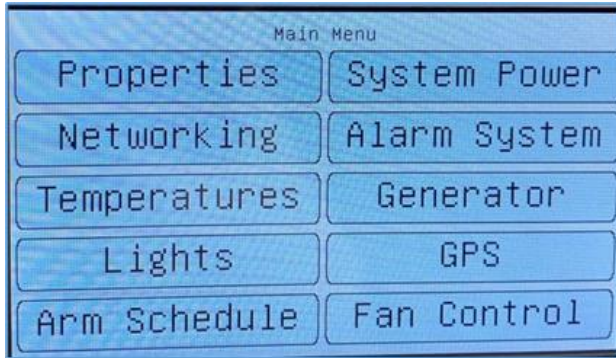

The Main Menu supports drill-down data for the noted system's functions.



The Properties screen provides the system's general information. The Power up time refers to the PCM. You may select the I2C Devices option for additional properties information or select the Main Menu option to return to the main menu.

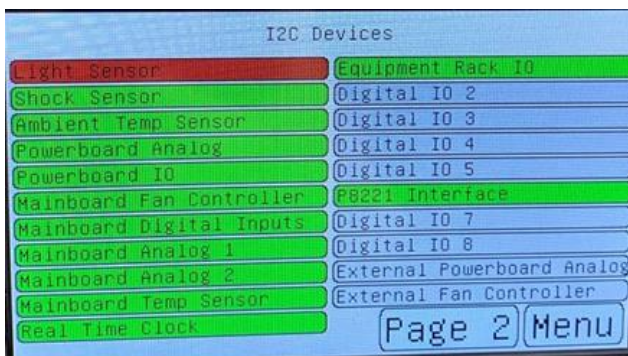

The I2C screen consists of two pages. This is a display of Page 1. This will display if the PCM finds additional external temperature sensors added with the I2C digital expansion interface. Up to 16 addressable temperature sensors can be added and the PCM will automatically discover and publish them to the LCD display on this page.

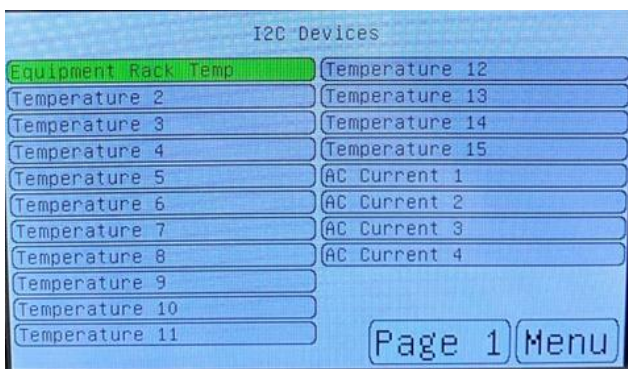

The I2C Devices screen consists of two pages. This is a display of the second page.



The Systems Power screen provides information on various systems components. The indicator in the upper right corner You may select the toggle option of “A” for amps for “W” for watts at the bottom of the screen. The Lights option is also available on this screen, just as it is available on the main menu screen.

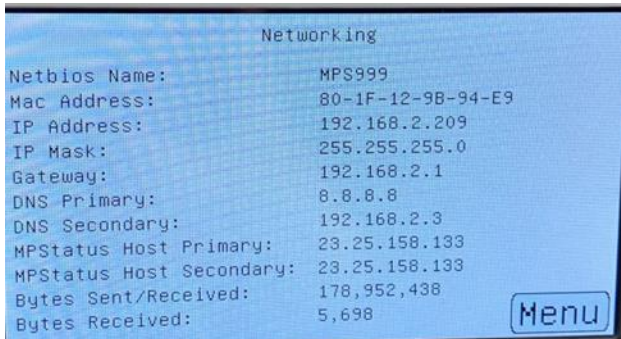

The Networking screen provides information relevant to the network, including the MAC Address and the IP network settings. Each trailer has a unique ID which is used when sending data to the MPStatus Dashboard. This screen also shows the IP address of this PCM on the local network with its associated net mask and gateway. The IP address of the gateway is usually the address of Cradlepoint modem in the trailer. The host IP address is address of the MPStatus Dashboard on the internet which is where the PCM sends its telemetry data to.

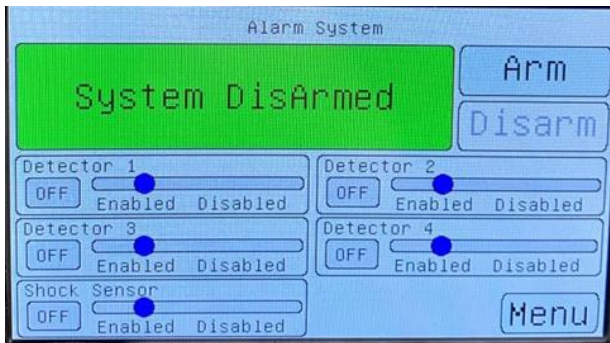

The Alarm System screen provides the user with the ability to enable or disable the system’s alarms and view the settings.

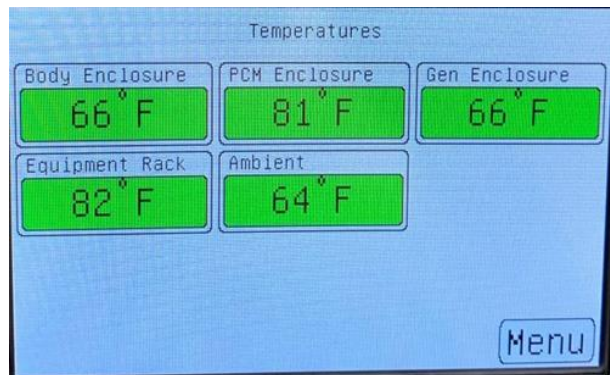

The Temperatures screen provides information relevant to the system’s temperatures. The Body Temp is the temperature inside the trailer body from the sensor plugged into the right side of the PCM. The PCM temp is the temperature inside the PCM enclosure. The Equipment Rack sensor is inside the Equipment rack on the Power Control Circuit Board. The Ambient temperature is the temperature outside the trailer.

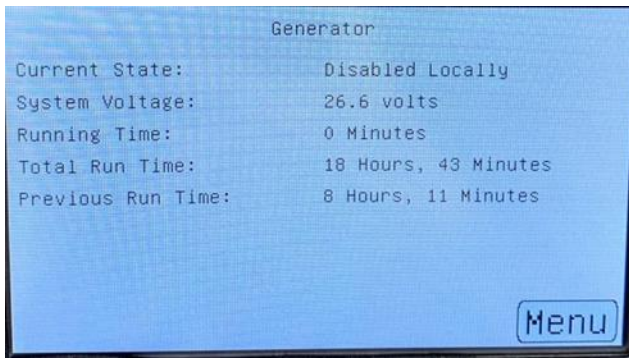

The Generator screen provides information relevant to the generator. The Current State shows the generator status. The Systems Voltage shows the voltage. The Running Time shows the generator's current run time. The Total Run Time shows the total amount of time the generator has run in total. The Previous Run Time shows how much time the generator ran from its most recent completed run.

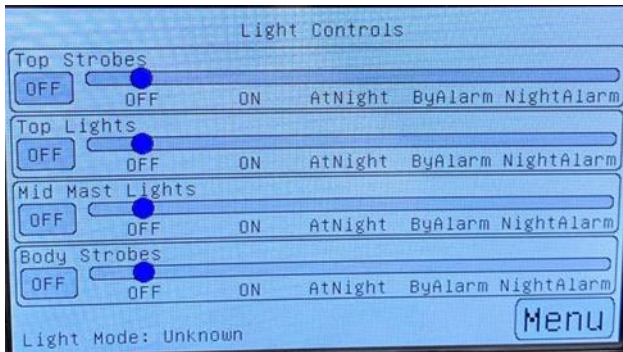

The Light Controls screen provides the user with the ability to view, schedule and enable or disable the various lighting controls on the system. These modes can be used to automatically control the operations of the lighting equipment that may be installed on the trailer.

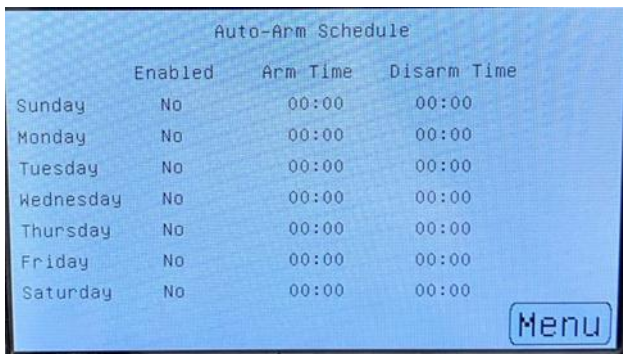

The GPS screen provides information relevant to the GPS coordinates. This page shows the GPS location in decimal degrees for latitude and longitude. The Altitude is displayed in feet above sea level. HDOP shows the horizontal dilution of precision. 1.0 is a very good HDOP, but as this value goes higher, the GPS location quality becomes worse. Sat shows the number of satellites being used to calculate the GPS location.

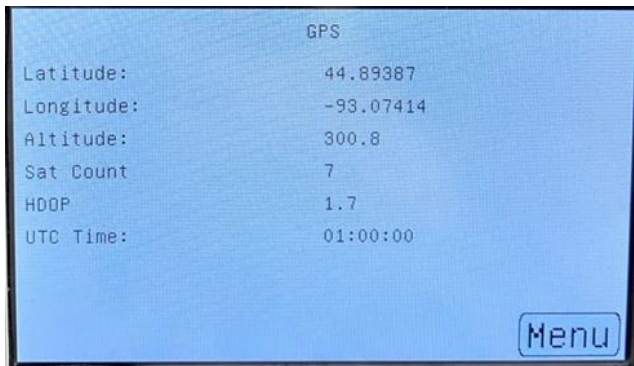

The Auto-Arm is an option that if included, is located on the midmast. The Auto-Arm Schedule screen provides the user with the ability to enable or disable the system's midmast arms by day and time.

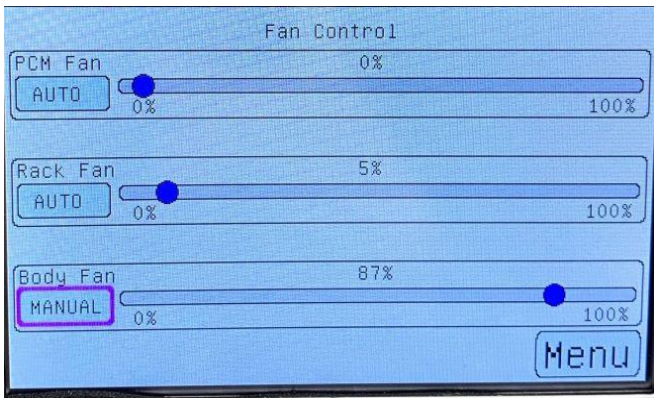

The Fan Control screen provides the user with the ability to control the system's various fans' settings. If there is a purple border and it says manual, this means that you have over-ridden this fan and it will not be in auto mode. To remove manual mode, press the purple border manual icon.

## Circuit Breaker Switches

Each of these circuit breakers provides overcurrent protection against accidental short circuits with the wiring in the PCM or with devices externally connected to the PCM. They also provide the operator a convenient way to turn off or on these circuits.

These breakers control the following circuits:

- 24VBATT; 100 amps: Connects to the 24-volt battery bank.
- 12VBATT; 100 amps: Connects to the 12-volt battery bank.
- WINCH; 50 amps: Connected to both winches for tilting and telescoping the mast.
- 24V SYS; 30 amps: Connected to all the devices controlled by the PCM except certain high-current devices that are controlled by Top Lights or Aux Power breakers. Turning on this breaker powers up the processor in the PCM and the trailer will operate if the batteries are on or the AC power is plugged in.
- 12V SYS; 20 amps: Connected to the high-current devices, typically lights, at the top of the mast or at the mid-mast. Most other devices that do not require high current levels to operate are powered from the 24V SYS Power breaker.
- AUX; 20 amps: May be connect to additional custom equipment installed in the trailer or it may not be connected to anything.

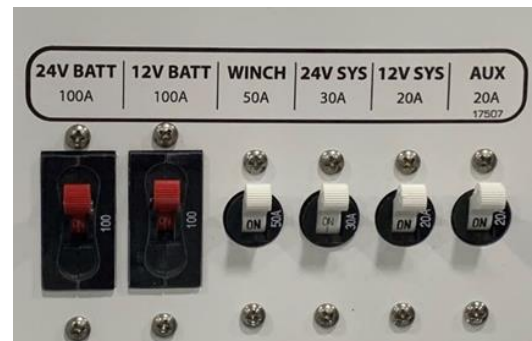

## Systems Power Control Switch

This switch has three positions - momentary UP to Turn the system on, Center is System normal operation, and momentary DOWN will place the system into Hibernate. IF the momentary DOWN is pressed twice the system will Hibernate and provide a “Full Shut-Down” and disconnect the batteries from the system. Hibernate means it will provide a “Soft Shut-Down of the computer, disconnect power to the cameras and active components, but leave the MPStatus control system active.



## Generator Control Switch

This switch has two set positions and one momentary position.

(UP) - The generator can also be manually started by holding the generator control switch in the up (Start Now) position for at least one full second. This will cause the PCM to enter the generator starting sequence.

DOWN - If the switch is moved to the downward position, it disables the PCM from automatically starting the generator. If this switch is down in the “Disabled” position, the PCM will automatically command the generator to stop. When placing a trailer inside a building, make sure to always move this switch down to the disabled position so that the generator will not start. Running a generator indoors can be dangerous as the generator will be producing carbon monoxide and other poisonous gasses.

CENTER - When this switch is in the middle position, it puts the generator in Automatic mode. In this mode, the PCM is monitoring the battery voltage levels. Once both battery banks stay less than 12.0 volts for at least 30 seconds, the PCM will begin a generator starting sequence. Note that this starting sequence is slightly different depending on which model of generator is installed in the trailer.

When the generator is running, the PCM monitors the battery charging levels and it will automatically shut off the generator when the batteries have been charged. Note that once the PCM starts a generator, it will run it for a minimum of 30 minutes and a maximum of 8 hours. While the generator is running, if the generator control switch is moved to the downward disabled position, the PCM will stop the generator.



## 4.3. POWERING UP THE TRAILER

- A. The normal power operation of the trailer is to use the system power control switch to control the power operations. See the operation for this switch above under "Systems Power Control Switch" . This should be used in Normal operations and the breakers should not be shut off if the trailer will be reused within a month or so.
- B. Powering the trailer if the batteries have been depleted or the breakers have been shut off.
  1. Open the passenger side door and locate the Power Control Module. The PCM (Power Control Module) is the white enclosure on the rear, passenger side of the trailer.

2. Ensure that all breakers are set to ON. Operate the “Systems Power Control Switch” by pulling the toggle UP, the battery banks will re-engage. Once power is applied to the PCM, the CPU will pause for three seconds before starting its normal operations. After three seconds, the PCM should be running and it will begin with a beeping sequence as well as flashing the side lights on the trailer body because the door is open and this beeping sequence always starts when a door is opened. The LCD display should show its initial startup screen.

*Note: Electrical breaker descriptions can be found on page 17.*

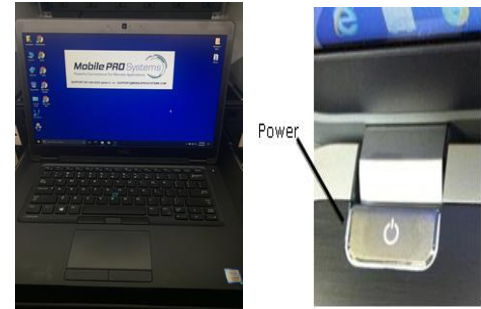

3. Switch the Generator Operation switch to AUTO (the center position).

*Note: when the Generator Operation switch is switched to AUTO (the center position), the generator will not immediately start when the system is powered on. The generator will only power on automatically when the battery voltage drops below a pre-designated voltage.*

Your configuration may differ dependent on the products selected.

## 4.4. COMMUNICATIONS

Please install all communication devices according to the specific product’s installation guide provided in Appendix A, Section V.

## 4.5. SHORE (LAND) POWER – OPERATION/BATTERY CHARGING

The MPS-3400 can always be charged by being plugged into a 110 VAC outlet. The 110 VAC connection is located on the back panel of the control enclosure. (Shown in External Connector Locations section 10.1). By plugging in shore power, it allows the system to operate directly and/or will serve to charge the battery banks.

## 4.6. POWERING DOWN

### SOFT SHUTDOWN

A soft shutdown will shut down the computer and set the system to hibernation mode. The soft shutdown is typically utilized for short periods of non-use.

1. Switch the Generator Operation switch to OFF (the bottom position).
2. Push the momentary System Power Control down once to shut down the system.

### FULL SHUTDOWN

A Full shutdown will shut down the computer, turn off all the active components and disconnect the battery banks. The full shutdown is typically used for long periods of non-utilization or if the system is put into long-term storage.

1. Switch the Generator Operation switch to OFF (the bottom position).
2. Push the momentary System Power Control down twice to shut down the system and disconnect the battery bank.

**NOTE: For very long-term trailer storage, ensure that all breakers are switched OFF.**

## 4.7. AUTOMATIC LOW-VOLTAGE BATTERY DETECTION

If the batteries in the trailer are allowed to completely drain to the point where there is absolutely no power left, it can damage the batteries internally and reduce their lifespan and efficiency. The PCM's processor is always monitoring the batteries and it will start the generator to charge them when they have depleted. If the generator fails to start for any reason, such as running out of gasoline or an equipment failure, the PCM will continue to operate and it will continue to try and start the generator. However, once it fails to start the generator after attempting 8 times, it will enter a lockout mode and no longer continue trying to start it.

The Voltage Monitoring system has 5 modes that it goes through while monitoring the battery voltage conditions.

The modes of operation are:

- **Normal** – This is when the system has enough power capacity and voltage to run the system normally.
- **Low Voltage** – The system has gone below the point where the generator or solar should have maintained voltage but didn't. everything still runs normally. The user could receive a notification of this mode.
- **Critical Voltage** – The batteries are below where it can operate normally and we start shedding power by turning off cameras, computer, lights etc. Although the communications are still operating.
- **Hibernate** – Voltage has reached a low point where it can't support even the communications hardware and it shuts this down, now only the base system operations are functioning. This can last for days.

**Full Shutdown** – Voltage is to a level that the batteries need to disconnect from the system so that the batteries will not degrade the life of the bank. Once this occurs, only a local restart will reactivate the system.

## 5. GENERATOR OPERATIONS

### 5.1. POWERING ON THE GENERATOR (AUTO)

When the generator is set to run on AUTO, the MPStatus OS computer system automatically powers on the generator when the battery power falls below a pre-designated voltage. Similarly, when the batteries are fully charged, the computer system shuts down the generator. The cycle will continue as long as the Generator Operation switch is on AUTO (the center position).

1. Begin by powering on the system with the System Power Control switch. Ensure that all the breakers have been switched to the ON position.
2. Switch the Generator Operation switch to AUTO (the center position).
3. MPStatus OS (Operating System) will then automatically start the generator when the batteries are low.

There are two common types of generators used in the MPS-3400:

- Cummins Onan 4000 KY unleaded gas generator, OR
- Power Tech PT-3SV2 diesel fueled generator.



### 5.2. POWERING ON THE GENERATOR FROM THE PCM (MANUAL)

To start the generator from the PCM follow the steps below.

1. Make sure the key is in the on position on the generator. Also make sure the fuel is switched on.
2. Back at the PCM hold the Gen Operation switch in the upward position.
3. After a few second the automated start sequence should begin.
4. If this does not work refer to the manual starting section.

### 5.3. GENERAL OPERATION

The generator's purpose is to charge the battery package and maintain the batteries within a 60% charge.

**Generator Start** - With the generator in automatic mode the system will start the generator, or 60% capacity of a full charge. The generator will continue to operate until one of the two conditions are met:

- Either the battery voltage maintains a voltage for a period of 10 minutes while the charge current into the battery bank is less than 8 Amps. Or,
- The charging process continues over 8 hours.

Any time the generator is in automatic start, the outside riding lights will flash for 8 seconds before it tries to crank. The automated start sequence will first, prime the generator for 3 seconds, wait for 2 seconds then crank the generator for up to 12 seconds.

**Minimum Run Time** - Once the generator starts, it will operate a minimum of 30 minutes. This includes manual starting. The manual start functionality will manually start the generator and place it into auto operation.

**Maximum Run Time** - If the charge process runs for over 8 hours, the generator will shut down and will give the battery bank 2 hours to stabilize before an automatic restart of the generator.

**Generator Lockout** – The generator will retry to start the generator up 5 times and will Lockout after the 5 times. It is advisable to provide an onsite visit to refuel, check oil, and electrical connections before retrying the generator start process. You can see this lockout condition on the remote MPStatus and control system. To clear the lockout situation locally switch the Generator control switch to the OFF position and back to auto for normal operation. One note is that if the generator is operating and you place the system to off, this may not stop the generator immediately. It needs to unload the gen first before shutting down.

## 5.4. FUELING

The fuel tank capacity of the unit is 20 US gallons. Do not overfill the fuel tanks! Trailers with black caps are for unleaded fuel and Green caps are for diesel fuel. Each trailer has a caution sticker near the gas cap displaying the correct fuel type to use.

- Cummins Onan 4000 KY unleaded gas generator.
  - Use ONLY regular un-leaded fuel.
- Power Tech PT-3SV2 diesel generator.
  - Use Diesel fuel only.
    - Use #1 Diesel below 30°F
    - Use #2 Diesel above 30°F



If the fuel is over filled, you may smell and see small amounts of fuel dripping from the fuel vapor canister vent hose that exists from each fuel pod through the floor.

## 5.5. MANUAL STARTING AND MAINTENANCE

For each style generator refer to Appendix B for manual starting procedures if the battery level is too low to run the MPStatus OS system.

Appendix B also shows a general maintenance frequency to keep your generator running at peak performance.

For generator maintenance details or error codes, consult the provided owner's manual specific to your generator.

## 6. POWER CONTROL MODULE OPERATIONS

The Power Control Module remotely monitors the current systems' status and automates the multiple inputs and outputs. Current conditions, along with recorded historical data and the desired output are combined to produce an efficient operating system.

### 6.1. ENCLOSURE TEMP

The PCM temp is the internal temperature of the PCM module. The rack temp is the temperature inside the modular rack mount enclosure.

### 6.2. GENERATOR STATUS

The Power Control Module detects and reports if the generator is operating or if it has failed to start.

## 7. RACK-MOUNT MODULE

The modular removable rack-mount system allows installation of standard rack mount hardware or individual components using a shelf mounting system. The rack-mount system can be quickly removed from the MPS-3400 by simply disconnecting the cables feeding the rack-mount enclosure at the rear of the enclosure. ***If the active component hardware includes electronics with moving parts such as hard drives, it is strongly recommended that the rack be removed for transport.***



Your exact configuration may differ dependent on the products selected.

Internal to the Rack enclosure is the power strip.



## 7.1. AC POWER CONTROL AND OUTLET POWER STRIP

This is typically powered from the inverter or directly from an external AC power source. It has a covered switch mounted on the rear face of the rack and is used to disconnect AC power to the components. Plug-in-style 120V power supply transformers used to power equipment should be secured to power outlets to limit the chance of loosening or falling out in transport.

## 7.2. HARDWARE DRAWERS AND MOUNTING SYSTEM

The rack-mount module enables quick attachment and removal of individual components embedded in the system. Hardware is typically mounted on a quick plate an aluminum mounting plate attached to the drawers for secure mounting for attachments. The drawers mount into the rack space. Each drawer incorporates 2 mounting positions with ½” standoffs. When installing new components, insure both front and back mounts are secured.

The MPS-3400 is equipped with one standard drawer. This drawer contains the mast cable terminations. The drawer slides in and out and incorporates “Slam Locks” that hold the drawer in the closed position. To release the drawer, pull both handles inward so it can be opened. Additional pre-configured drawers are available from Mobile Pro Systems.

# 8. TRAILER DEPLOYMENT

## 8.1. DAILY INSPECTION

- Inspect condition of electrical cords. **DO NOT** use mast if insulation is cut or worn through.



- Check that winch cables are in good condition and that they are centered on each pulley. **DO NOT** use a cable that is kinked or starting to unravel.
- Check that the safety pin for the mast cradle is present and secured with a chain.
- Check that the spring located in the mast lock bar is not broken or missing. Check the operation of the mast lock bar.
- Check the fuel and oil.
- Check the wheel lugs. Tighten or replace any that are loose or missing. If a tire has been removed for axle service or replaced, tighten the lugs in the order shown below, to the following specifications:
  - A. Start all lug nuts by hand.
  - B. First pass; tighten to 20-25 Ft-Lbs. (27-33 Nm).
  - C. Second pass; tighten to 50-60 Ft-Lbs. (67-81 Nm).
  - D. Third pass; tighten to 90-120 Ft-Lbs. (122-162 Nm).

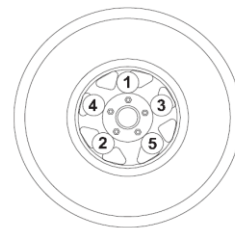

Do not exceed 120 Ft-Lbs. After the first road use, re-torque the lug nuts in sequence.

## 8.2. TOWING THE TRAILER



### WARNING

**Mast should be secured with the mast cradle locking pin in the mast cradle. Solar panels should be folded together, and the travel pin should be in place.**

### CAUTION

**NEVER transport the trailer system with cameras, communications, or any other removable devices attached.**

As the trailer travels down the road the mast will vibrate, and removable hardware may loosen and fall off. This can cause severe damage to the devices. Once the system is shut down and the cameras and other hardware is removed and properly stowed, the trailer can be made ready for transport.

1. If the tongue was removed place the tongue back into the slot and replace the red handled pin.
2. Reconnect the trailer lights cable to the trailer.
3. Reconnect the break disconnect carabiner from the tongue to the small key ring under the front of the trailer. See Leveling Trailer section for more details.
4. Deploy the tongue jack.
5. Raise the outrigger jacks completely and release the outrigger jack locking pins to swing the outrigger jacks up into the travel position. Make sure the locking pins snap into place.
6. Release the outrigger locking pins and slide the outriggers out to the first latching point about 1" from the frame. Ensure that the Latch Pin enters the latching point on the outrigger.
7. Use the tongue jack to raise or lower the trailer onto the hitch of the towing vehicle. Lock the hitch coupling and attach the safety chains to the vehicle. Release the tongue jack locking pin and rotate the tongue jack into the travel position. Make sure the locking pin snaps into place.
8. To ensure proper operation of the jacks, lube the grease fittings located on the leveling jacks.
9. Connect any trailer wiring to the tow vehicle. Check for proper operation of the stop and signal lights.
10. Make sure the mast cradle locking pin is in place.
11. Make sure the doors are properly latched.
12. Check for proper inflation of the trailer tires. The maximum tire inflation is 65 psi cold.
13. Maximum recommended speed for highway towing is 55 mph. Recommended off-road towing speed is not to exceed 10 mph or less depending on terrain.

## 8.3. LEVELING THE TRAILER

For maximum camera coverage, place trailer in a location where the deployed mast will be higher than the area being monitored.



### WARNING

**The tower extends up to 36 feet (11m). Make sure area above the trailer is open and clear of overhead wires and obstructions.**

1. Place the trailer on firm ground that is relatively flat. This will make it easier to level the trailer.
2. Disconnect the trailer plug and the chains connecting the truck to the trailer.
3. Pull the locking pin on the tongue jack and rotate it until the jack pad is facing down and spring- loaded pin snaps back into place (A).
4. Turn the jack handle clockwise to raise the trailer tongue off of the towing vehicle.
5. Pull the locking pins (B) on the outriggers and pull the outriggers out until the spring loaded locking pin snaps back into place this is the first position, about 15". There are two outrigger positions past this point. It is recommended the outriggers are NOT fully extended for maximum stability.
6. Pull the locking pin on the outrigger jacks and rotate until the jack pads are facing down and the spring loaded pin snaps back into place. Rotate the outrigger until the pad touches the ground.
7. Repeat steps 5 and 6 for all four outriggers.
8. There are two levels on the trailer. One in the back next to the mast cradle and one in the front next to the tilt point. To level the trailer, adjust the height of the outriggers until both levels show the trailer is level.
9. At this point if desired the tongue can be removed.
  - a. First disconnect the trailer running lights by simply pulling it out of the trailer socket.
  - b. The next connection is important it is the breakaway brake system. There is a small box mounted under the trailer near the tongue. Connected to this box is a pin attached to a key ring. Also attached to the keyring is a carabiner. When disconnecting the tongue, remove the carabiner from the key ring do not remove the pin. If the pin is removed for a long period of time, the internal battery for the electric brake system will die.
  - c. Finally remove the cotter pin from the red handled pin and remove the red handle pin from the trailer.
  - d. The tongue can now be removed from the trailer.

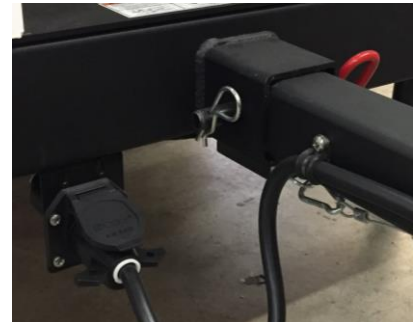

**CAUTION: DO NOT USE THE JACKS TO LIFT THE WHEELS OFF THE GROUND.  
\*\* JACKS ARE ONLY INTENDED FOR STABILIZATION. \*\***

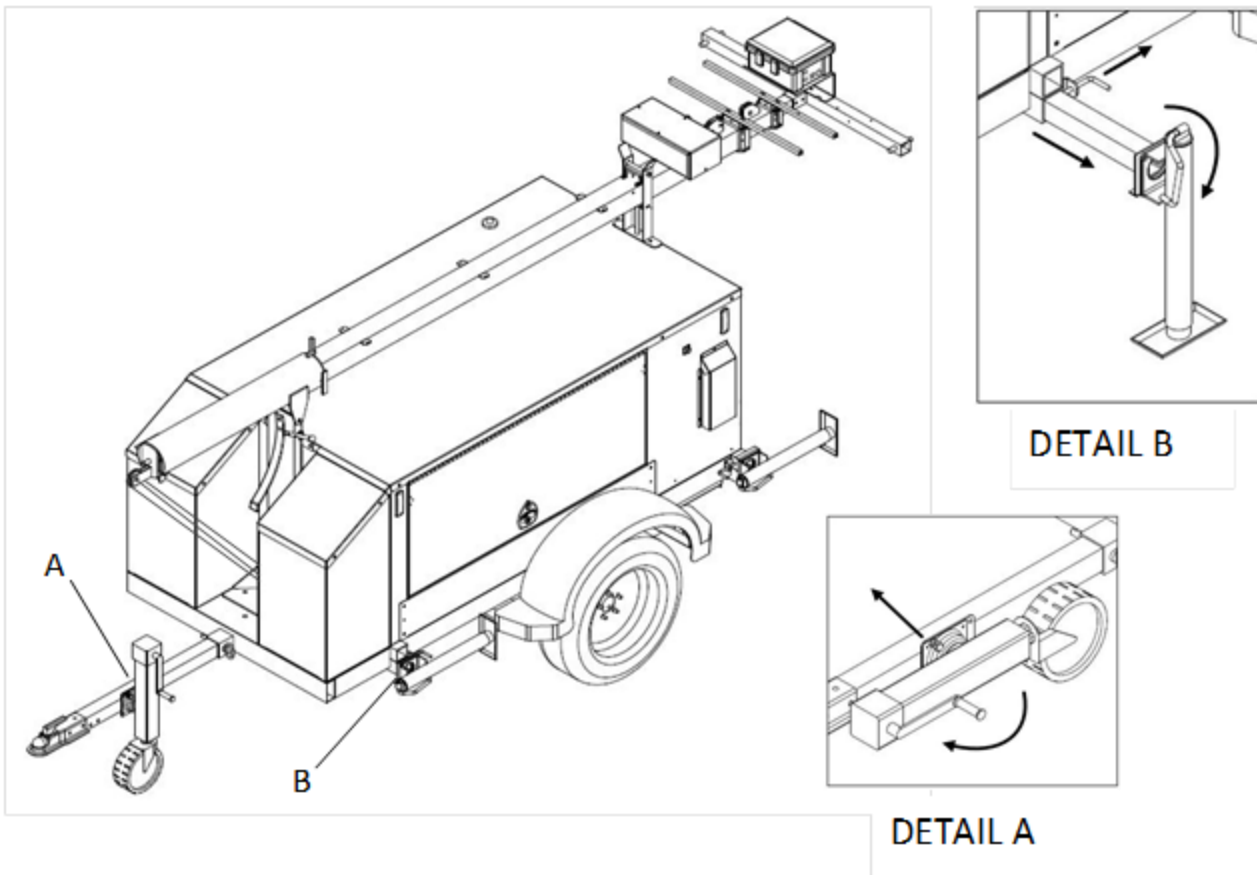

## 8.4. MOUNTING COMPONENTS

There are several different component set-ups. For general camera mounting see section on General Operations. For specific mounting positions for various set ups see Appendix A.

## 8.5. RAISING THE MAST



### WARNING

The trailer must be leveled with the outriggers extended before raising the mast. The outriggers must remain extended while the tower is up. Failure to level the trailer or extend the outriggers will severely reduce the stability of the unit and could cause the tower to tip and fall.



### WARNING

Do not start the unit if the insulation on the electrical cords is cut or worn through. Bare wires in contact with the mast or frame may energize the trailer and cause electrocution. Repair or replace cord.

1. Set up and level the trailer and mount equipment as described on page 12.
2. Check both sets of mast cables for excessive wear or damage. Make sure the cables are properly centered in each pulley. Check electrical cords for damage.
3. Remove the mast cradle locking pin from the mast cradle (C).

4. Make sure the area behind the unit is clear before raising the mast to the vertical position.
5. Press the lower winch control toggle switch labeled **TILT** upward to raise mast into the vertical position. Hold switch until the mast lock is engaged. The mast lock should snap into place automatically.

**Note:** Typical Mobile Surveillance Trailers are equipped with an electric winch, a limit switch on the mast tube will disconnect power to the winch to prevent deadheading the winch.

6. Press and hold the upper winch control toggle switch labeled **EXTEND** upward to telescope the mast to desired height. Extend the mast slowly; making sure that the coiled electrical cord is extending at the top sections of the mast. If, for any reason, the winch cable begins to develop slack or any of the tower sections get stuck, **STOP IMMEDIATELY** and contact an authorized service center.
7. If desired the mast can be rotated by loosening the locking knob at the bottom of the mast (E). Then turn the mast to the desired direction and then re-tighten the knob.



**Note:** Typical Mobile Surveillance Trailers are equipped with an electric winch, a limit switch on the mast will disconnect power to the winch to prevent over extension of the mast.

## 8.6. LOWERING THE MAST

1. First check if the mast has been rotated. If the mast has been rotated loosen the locking knob (E) and return the mast to its forward position. Then retighten the locking knob.
2. Press and hold the **EXTEND** switch in the down position to telescope the mast to its lowest height. It is crucial to watch the mast as it comes down. When the mast has reached its bottom limit release the **EXTEND** switch.



### **WARNING**

**Always watch the mast when lowering.  
There is no disconnect switch to stop the winch from continuing.**



### **WARNING**

**Never raise or lower the mast while the unit is operating!  
Never remove the mast lock while the mast is up.  
Releasing the lock will cause the mast to fall.**

3. To tilt the mast back into travel mode you must release the mast lock (D) by holding down the lever. While holding the lever down hold the **TILT** switch in the lower position to tilt the mast. Once the mast starts moving the mast lock can be let go. Continue lowering the mast until it rests in the mast cradle then release the switch.

**Note:** A limit switch inside the trailer will disconnect power to the winch to prevent over tilting of the mast.

4. Return the mast cradle locking pin to the mast cradle.

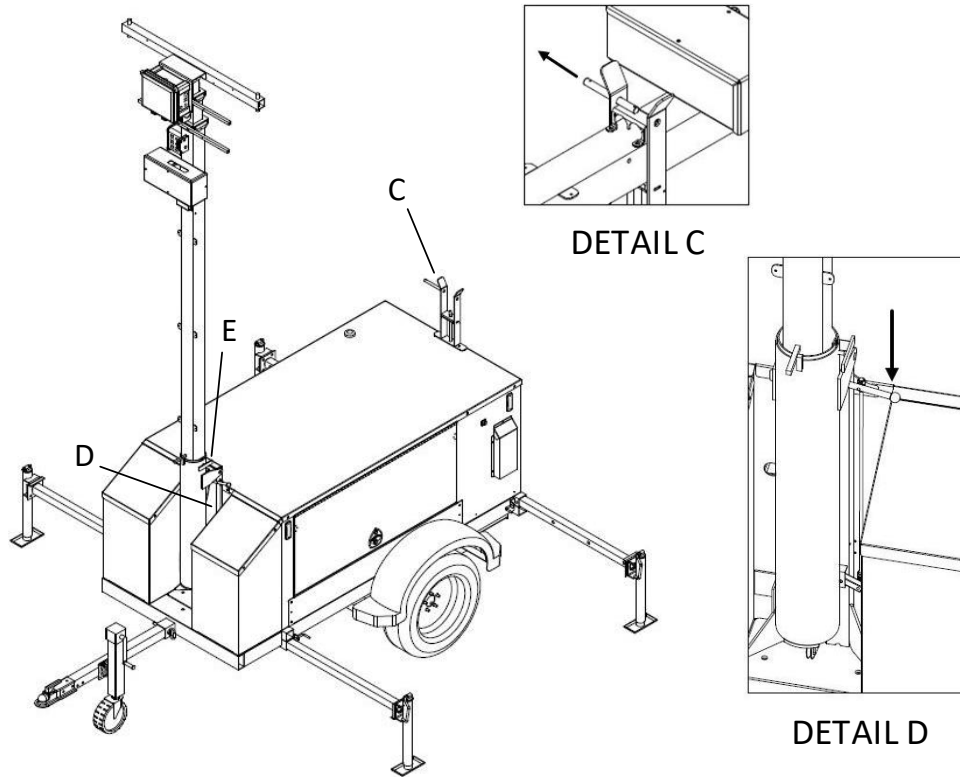

## 9. PREVENTIVE MAINTENANCE SCHEDULE

### 9.1. JACK MAINTENANCE

The following procedures should be performed at least annually:

1. Frequent maintenance may be needed on the front wheel swivel jack. The inner tube requires lubrication. You will notice that the wheel does not caster well, and the wheel tends to drag across the ground. This is when you need to fully extend it and coat the inner tube with lubricant. The recommended lubricant is garage door pro lube.
2. For side-wind models, the internal gearing and bushings of the jack must be kept lubricated.
3. Apply a small amount of automotive grease to the internal gearing by removing the jack cover, or if equipped, use a needle nose applicator or standard grease gun on the lubrication point found on the side of the jack near the crank.
4. Rotate the jack handle to distribute the grease evenly. Lightweight oil must be applied to the handle unit at both sides of the tube for side-wind models.
5. If equipped, the axle bolt and nut assembly of the caster wheel must also be lubricated with the same light weight oil.
6. For top-wind models, apply lightweight oil to the screw stem.

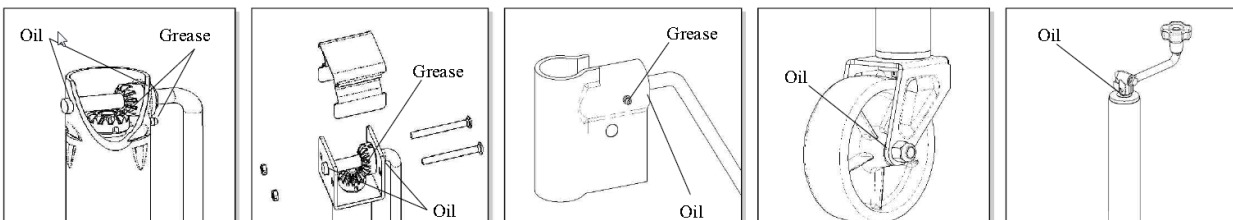

\*Conduct maintenance activity after the first operation, before each use, Semi-annually, or after each 25 hours of operation:

General Maintenance Activity	Before each use	Quarterly	Annually
Check cables	X	X	
Check jacks	X	X	
Check camera mountings	X	X	
Check fasteners*	X		
Visual check of winch and control*	X		
Check electrical connections*		X	
Clean and grease brake assembly*		X	
Check motor brushes*		X	
Change engine oil (see generator manual)		X	
Minimal check tire pressure		X	
Grease axle bearings			X
Oil points above			X
Check battery connections			X

## 9.2. WINCH MAINTENANCE

- Keep winch free of dirt, oil, grease, water and other substances.
- Check all mounting bolts and make sure they are tightened to the recommended torque values. Replace any damaged fasteners.
- Periodically check all connections to be sure they are tight and free of corrosion.
- Check cable for visible damage every time winch is operated. Examples of damage are: cuts, knots, mashed or frayed portions, and broken strands. Replace cable immediately if damaged. Failure to replace a damaged cable could result in breakage.
- Regularly check brake for slippage or drift. This is detected visually when winch is under load. If winch drum continues to turn after controls are released, brake may need to be replaced.
- Periodically clean and grease brake assembly. This will ensure proper performance and extend the life of the winch. If winch seems to labor or get excessively hot during the lowering of loads, the brake will need to be serviced or replaced.
- Check motor brushes periodically and replace when necessary.

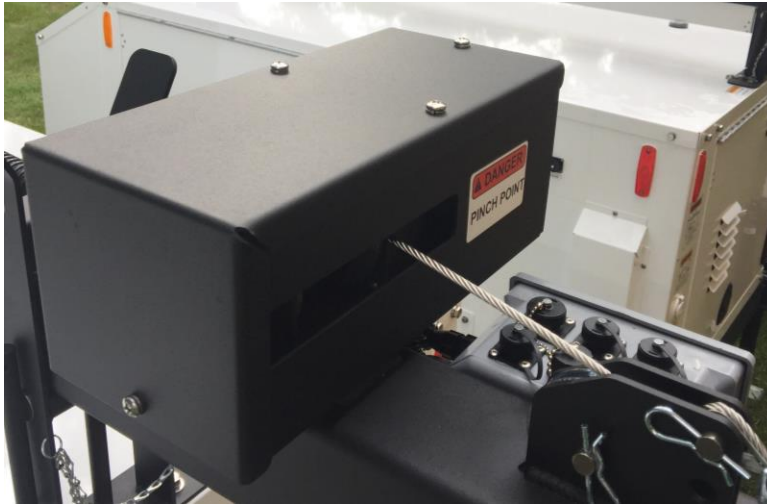

**Note:** The motor brushes and brake assembly may require periodic replacement. Although cables require replacement if any damage or corrosion is present!

### 9.3. BATTERY OPERATION & MAINTENANCE

The MPS-3400 typically uses 100AH AGM batteries. It is important to review the Material Safety Data Sheet (MSDS), battery operation and maintenance manuals from the battery manufacture. These may also be supplied with the battery package. Contact Mobile Pro Systems for more battery information.



#### **WARNING**

**Use extreme caution when servicing the battery packages.  
Never enter into a situation where a conductive object can short the batteries.**

A 1,200 Amp Hour battery package stores an enormous amount of energy. Shorting the batteries could instantly vaporize the tool or object that you are using, causing extreme burns, serious injury or worse.

- Ensure that there is not any damage the batteries exterior.
- Ensure that the batteries have not moved from their normal position during travel.
- Check the battery brackets to ensure that the battery holder brackets are tightly screwed down.
- Closely inspect each battery's connection for corrosion.
- Test each battery connection point and ensure that they are tight and do not show any sign of wear.
- If any corrosion is present, immediately stop the operation of the system and correct the issue.

#### **Battery operation:**

This manual is based on the typical Qty 13 – 100 AH AGM Battery configurations (12 for the 24v system, 1 for the Generator Cranking and Mast Operations).

Your configuration may be different.

Battery Type:

Lead acid GEL AGM (Absorbed Glass Mat)

Long life, spill free, maintenance free, minimal vapor, physically stable, minimally corrosive, wide operating temperature range, best performance.



**WARNING**

**Never mix battery types or age. Use only one size, type, and age of battery.**

Battery age is important. As the battery ages the chemistry changes and it will have a different charge profile. When you need to change out a single battery and the bank is over 2 years old, consider changing the entire pack or at least a significant number of the batteries. If a single battery is changed out, that battery will charge at a higher rate and could heat excessively causing a serious situation.

Batteries will self-discharge over time. It is recommended that the batteries be maintained by leaving the charger operational during storage.

**Never try to service your system without the correct information!**

# 10. CONNECTOR LOCATIONS AND WIRING DIAGRAMS

## 10.1. EXTERNAL CONNECTOR LOCATIONS

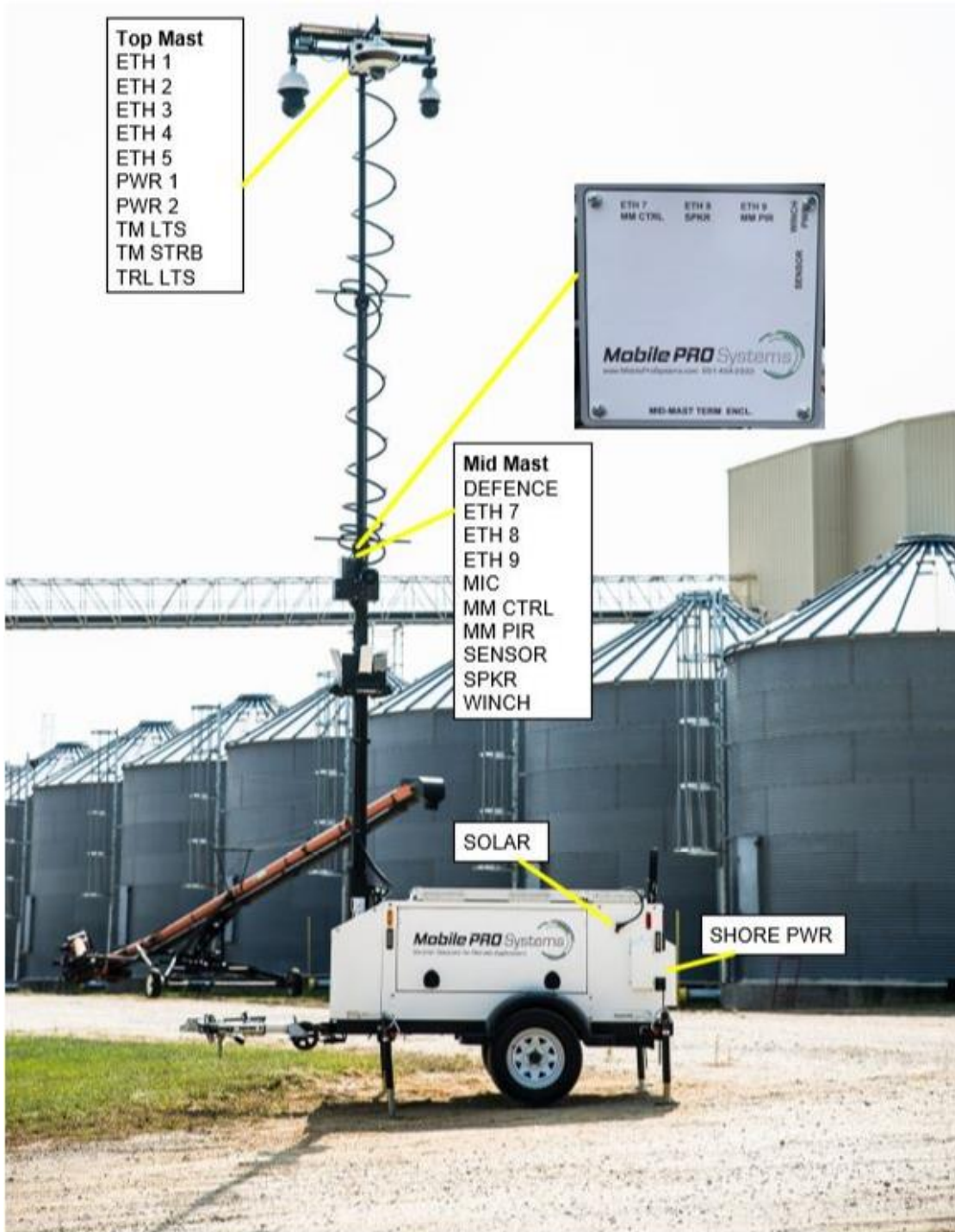

Your exact configuration may differ dependent on the products selected.

## Top Mast Box

**ETH 1** – An Ethernet connector typically used for Camera 1.

**ETH 2** – An Ethernet connector typically used for Camera 2.

**ETH 3** – An Ethernet connector typically used for Camera 3.

**ETH 4** – An Ethernet connector typically used for Camera 4 or a communication device.

**ETH 5** – An internal Ethernet connection typically used for a Cradlepoint or another network connection.

**PWR 1** – An internal power connection typically used for a Cradlepoint or another network connection.

**PWR 2** – Uses 2 pins of a 4-pin connector typically used to provide extra power to a camera.

**TM LTS** – A 3 pin connector typically used to power the top mounted bar lights.

**TM STRB** – A 4 pin CPC connector typically used for the top mast strobe lights.

**TRL LTS** – An internal connection to the clearance light mounted to the top mast box.

## Mid Mast Box

**DEFENCE** – An internal connection used for the DEFENCE alarm/disarm LED.

**ETH 7** – An Ethernet connector typically used for camera.

**ETH 8** – An Ethernet connector typically used for camera.

**ETH 9** – An Ethernet connector typically used for camera or audio device.

**MIC** – An internal connection used if a microphone is added to the mid mast.

**MM CTRL** – A 4-pin connector used as an Auxiliary Control.

**MM PIR** – Uses 8 pins of a 9-pin connector combining MOTION and MM LTS. Typically used for the Mid Mast PIR kit.

**SENSOR** – A connection controlling the mast sensor to limit the extension of the mast.

**SPKR** – A connection typically used for a speaker.

**WINCH** – A power connection used to power the winch controlling the telescoping mast.

## Body

**SHORE PWR** – An AC outlet typically used to charge the trailer from an external source.

**SOLAR** – A connection between the optional solar panels and the trailer body.

Your configuration may differ dependent on the products selected. These are just typical applications of each connection point.

# 10.2. POWER CONTROL MODULE

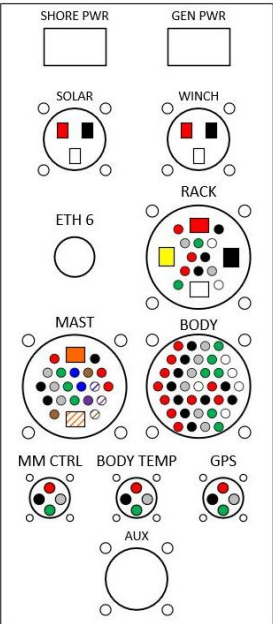
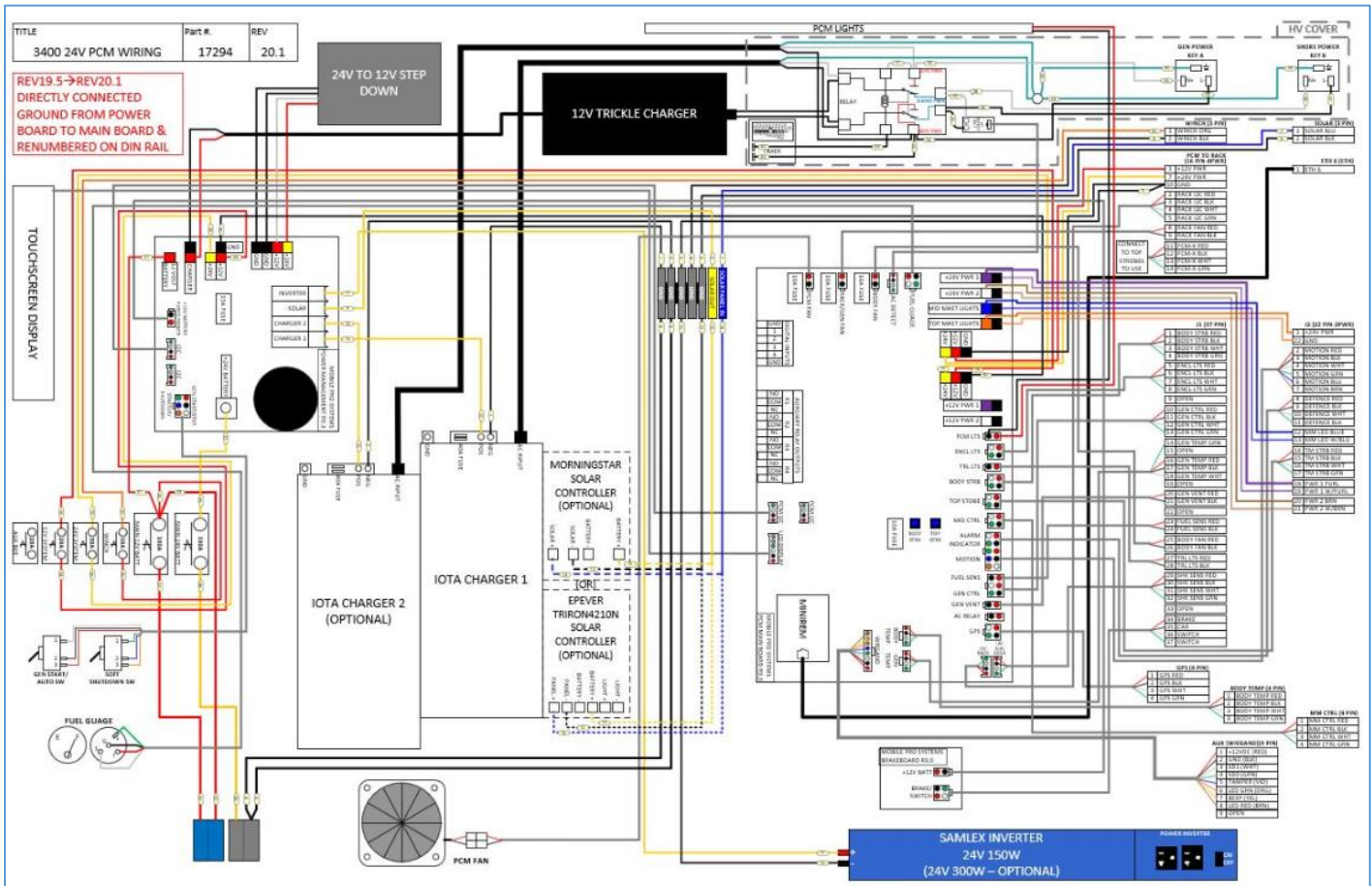

- SHORE PWR** – Connect the PCM to the shore power external connection point.
- GEN PR** – Connects the PCM to the generator AC power.
- SOLAR** – Connects the PCM to the solar external connection point.
- WINCH** – Connects the PCM to the winch box
- ETH 6** - Connects the PCM to the Rack via an ethernet cable.
- RACK** – Supplies power and data lines to the Rack from the PCM.
- MAST** – Sends power and signal to equipment mounted on the Mid Mast and Top Mast.
- BODY** – Controls internal equipment such as body strobe lights, enclosure lights, generator control, generator fan, generator temperature sensor, generator vent, fuel gauge sensor, enclosure fan, and the trailer lights.
- MM CTRL** – Connects the PCM to the Mid Mast box for an extra control line.
- BODY TEMP** – Controls an internal temperature sensor.
- GPS** – Connects the PCM to a GPS.
- AUX** – Typically used to connect an external device, such as a keypad or card reader.

# 10.3. BODY PINOUTS ON THE POWER CONTROL MODULE

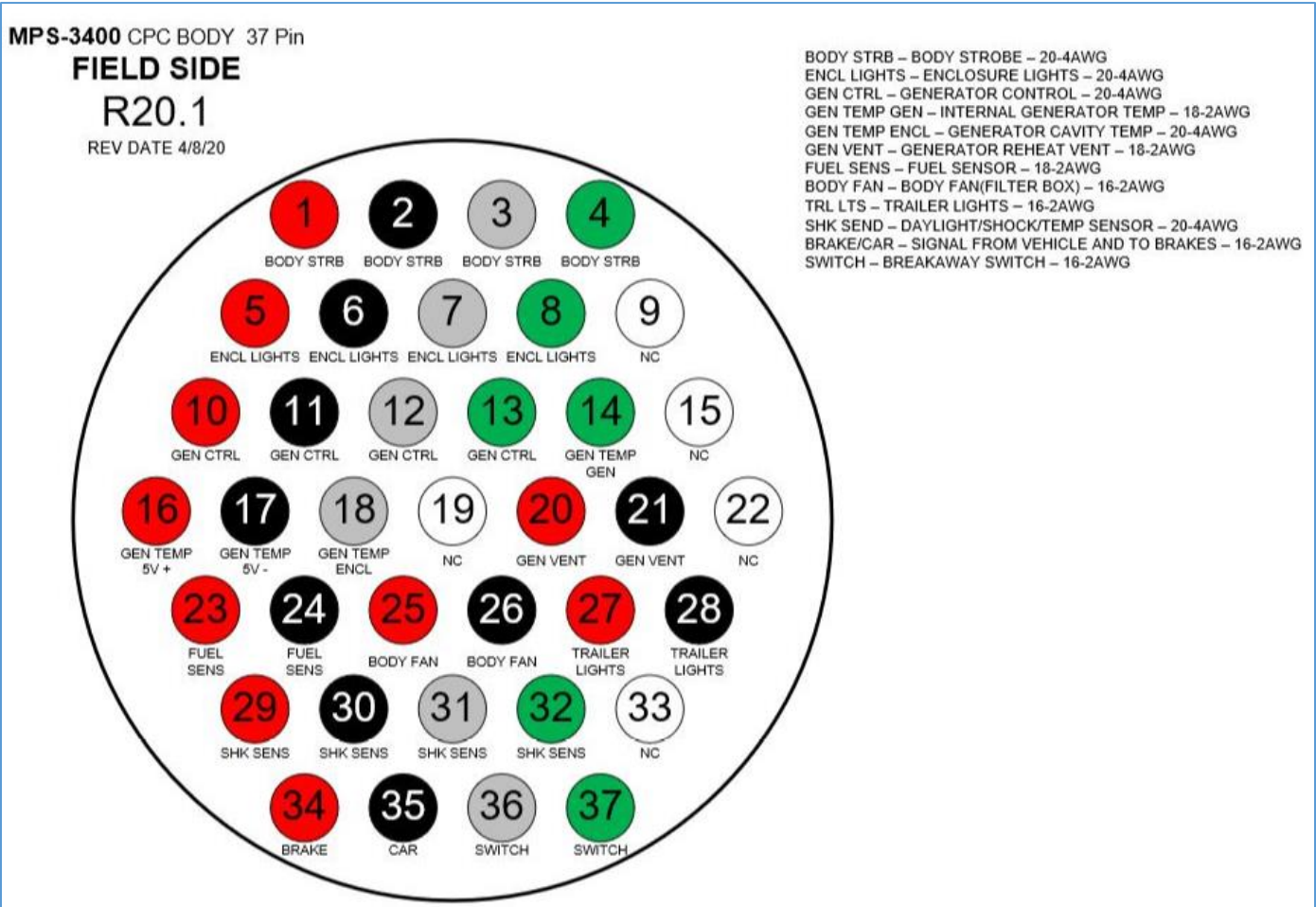

Your exact configuration may differ dependent on the products selected.

## 10.4. RACK BOARD

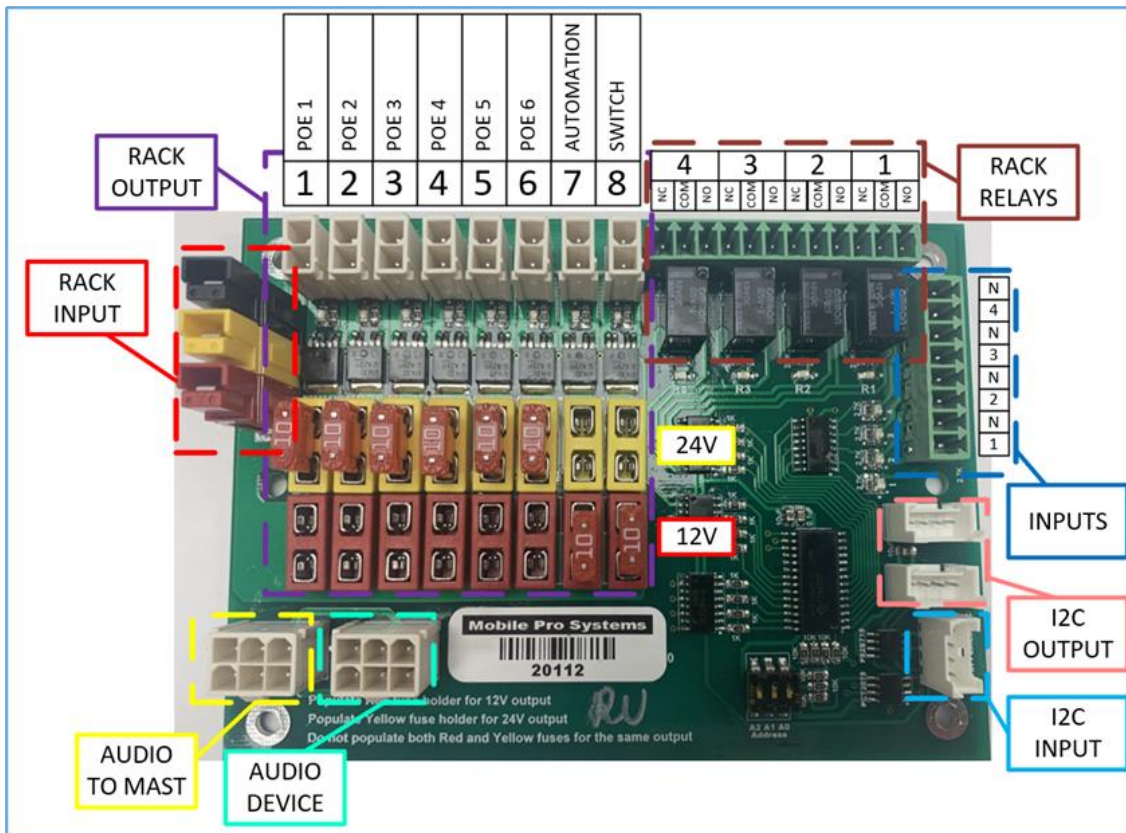

Your exact configuration may differ dependent on the products selected.

**RACK INPUT:** The rack input power to the board is sourced from the PCM. There are 3 connection points Red-12V, Yellow-24V and Black-Common ground.

**RACK OUTPUT:** There are 8 power outputs. Each output can independently be 12V or 24V. The voltage for each output can be changed by moving the 10 Amp fuse to the preferred fuse holder. The red fuse holders represent 12V and the yellow fuse holders represent 24V. Referencing the picture above, the six outputs (1-6) on the left will have 24V. In addition, the two outputs (7-8) on the right will be 12V. Each of these outputs can be controlled from the control tab on MPStatus. Control options allow the user to remotely turn on, off, or cycle each output.

**Caution: Do not populate both red and yellow fuses for the same output!**

**RACK RELAYS:** There are 4 rack relays that can be remotely controlled from MPStatus. Note these are 1 Amp relays. Connect the device to the common then choose the normally open or normally closed side to send a signal back to the device.

**Inputs:** Optional inputs are provided as pull to ground inputs. Connect a device to allow MPStatus to see the input.

**AUDIO TO MAST:** Some units may have audio capabilities. A microphone and speaker may be mounted to the mid mast. This board is the connection point to them. Pins 1 & 2 are for the speaker. Pins 3, 4, & 5 are from the microphone. Pin 5 is the shielded.

AUDIO DEVICE: If audio devices are present on the unit use this 6-pin connector. Pins 1 & 2 are for the speaker. Pins 3, 4, & 5 are from the microphone. Pin 6 is the shielded.

I2C INPUT: I2C is provided from the PCM to the rack to provide control opportunities to the main system.

I2C OUTPUT: I2C device can be linked to the system by connecting the new device to these connection points.

## 10.5. ENCLOSURE LIGHTS DIAGRAM

The enclosure lights are LED strip lights, and the switches are normally closed. When the door is opened the switch opens and turns on input 1 of the controller. The controller turns on Relay 1 of the controller which powers the LEDs.

The switches are also used to indicate System Tamper when the doors open.

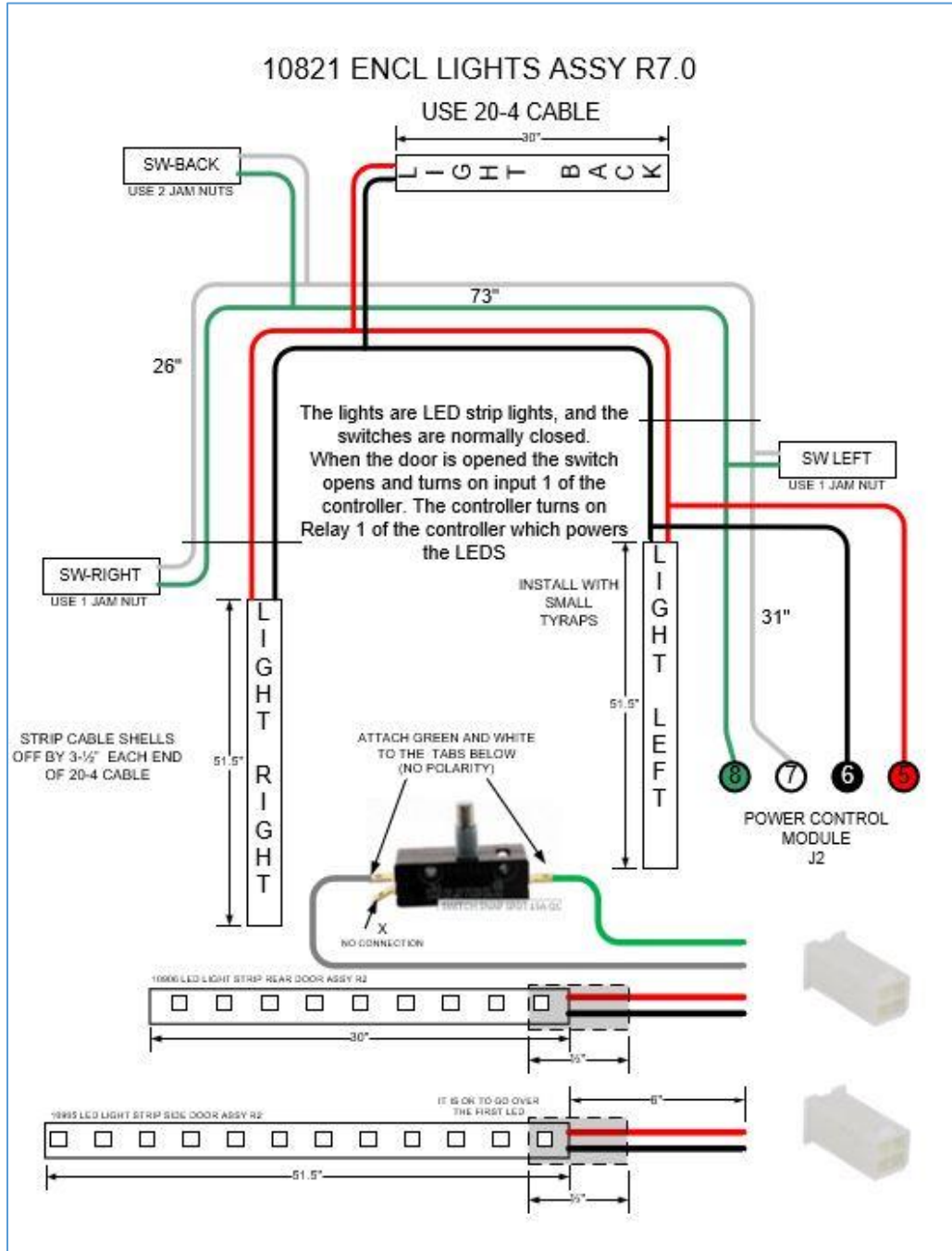

Your exact configuration may differ dependent on the products selected.

# 10.6. TRAILER EXTENSION CABLE AND PRODUCTION WIRING

The trailer extension cable should be free from any faults.  
 This cable is a coil cable should be left in a coil form when not in use.  
 Unplug this cable from the truck and trailer body to remove tongue.

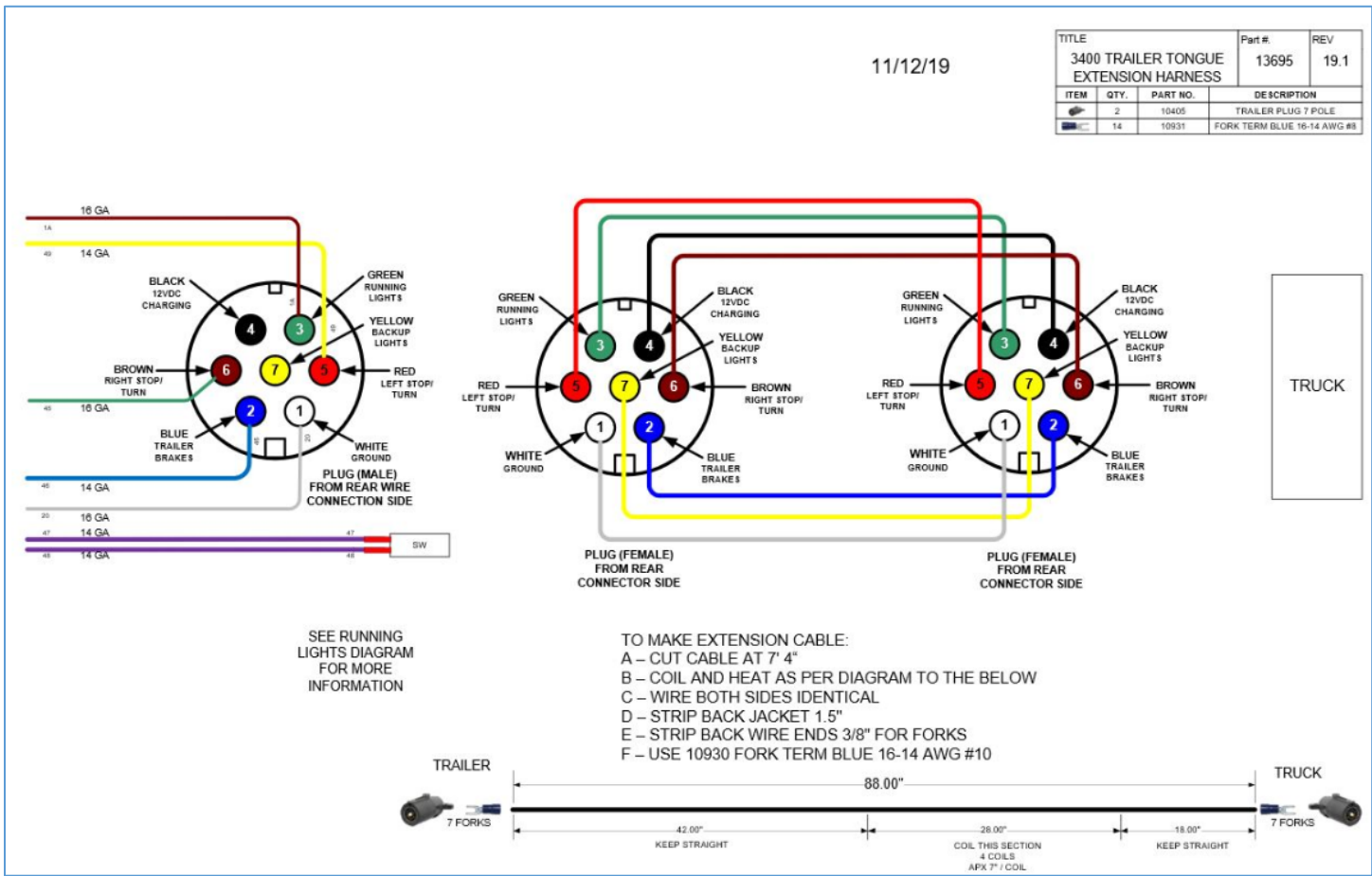

Your exact configuration may differ dependent on the products selected.

## 10.7. WINCH LIMIT SWITCHES

There are 3 mast limit switches they indicate if the mast is in the vertical position and if it is extended completely.

There is a Cable Slack switch inside the enclosure directly below the winch. This switch indicates that the mast is down, and the cable is going slack. The Cable Slack switch indicates for the systems to stop the winch motor in that direction, it is either down or there is an issue, do not uncoil the cable.

The Vertical Mast switch is located outside of the trailer between the fuel tanks. It opens when the mast is in a total vertical position which indicated to the system that it should stop the winch so that the user does not overload the winch motor.

At the top of the first mast section an ultrasonic proximity switch indicates when the mast is fully extended and should shut off the extension winch motor in that direction. If the motor does not stop a safety stop will catch the mast but stop immediately if the winch sounds like it is not working properly. Then an adjustment is required.

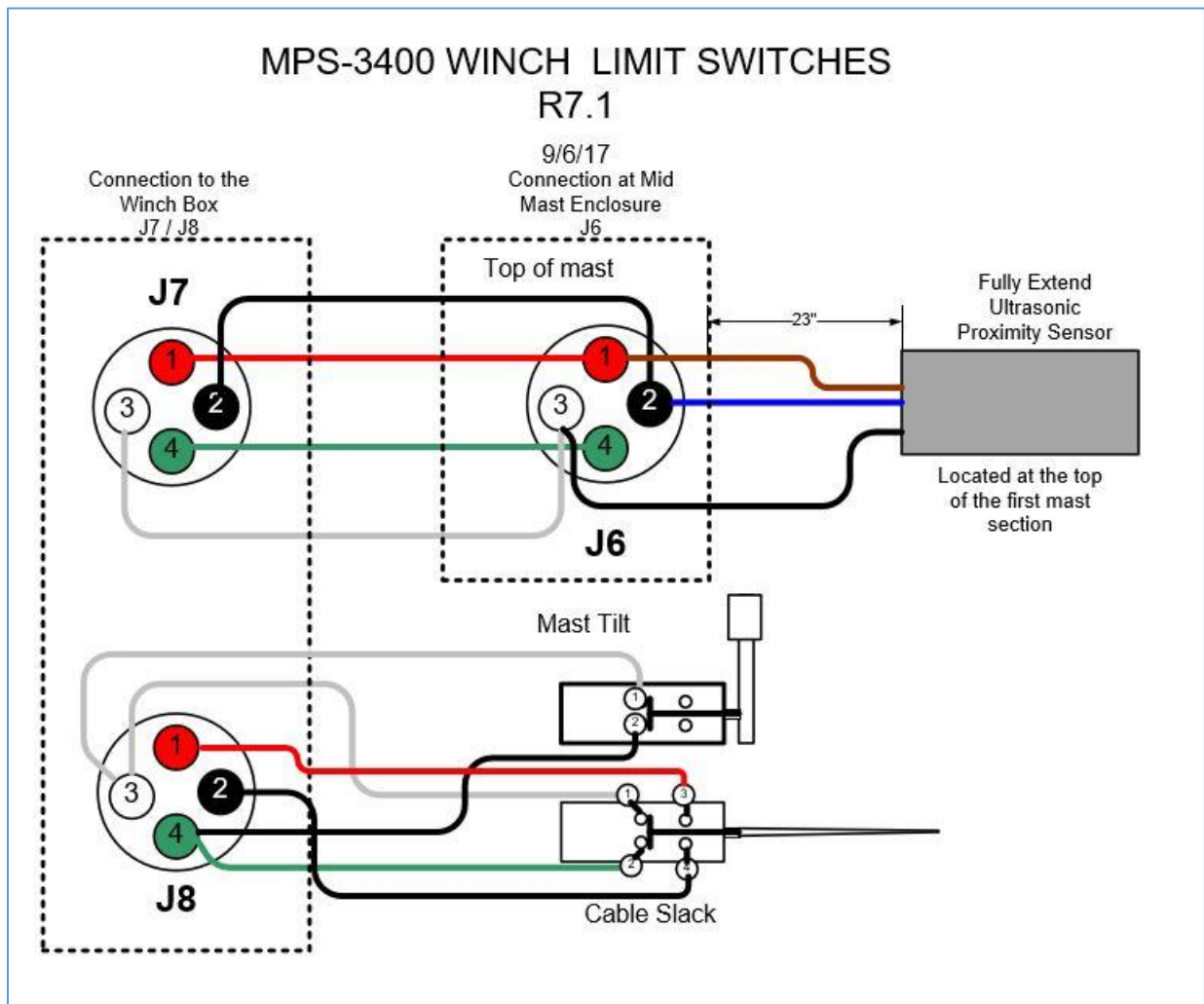

Your exact configuration may differ dependent on the products selected.

## 10.8. WINCH CONTROL WIRING

The winch control is located within the 4"x4"x4" gray enclosure mounted on the Winch Base Plate. It controls the two winches one for the tilt and the other for the extension of the mast. The enclosure has some logic components and power relays that provide on demand power to the motors. The system includes two power connectors, the red connector provides power to the module from the Power Control Module and the second blue connector feeds power to the mast motor. There are also 2 ring terminals that power the tilt winch. There are two 4 pin CPC connectors one male and the other female. The female CPC connector simply connects to the Inductive proximity sensor at the mid mast location. The other connector connects to the Mast Vertical Sensor and the Mast Cable Slack Switch. There is one 9 pin connector that runs to the switch control.

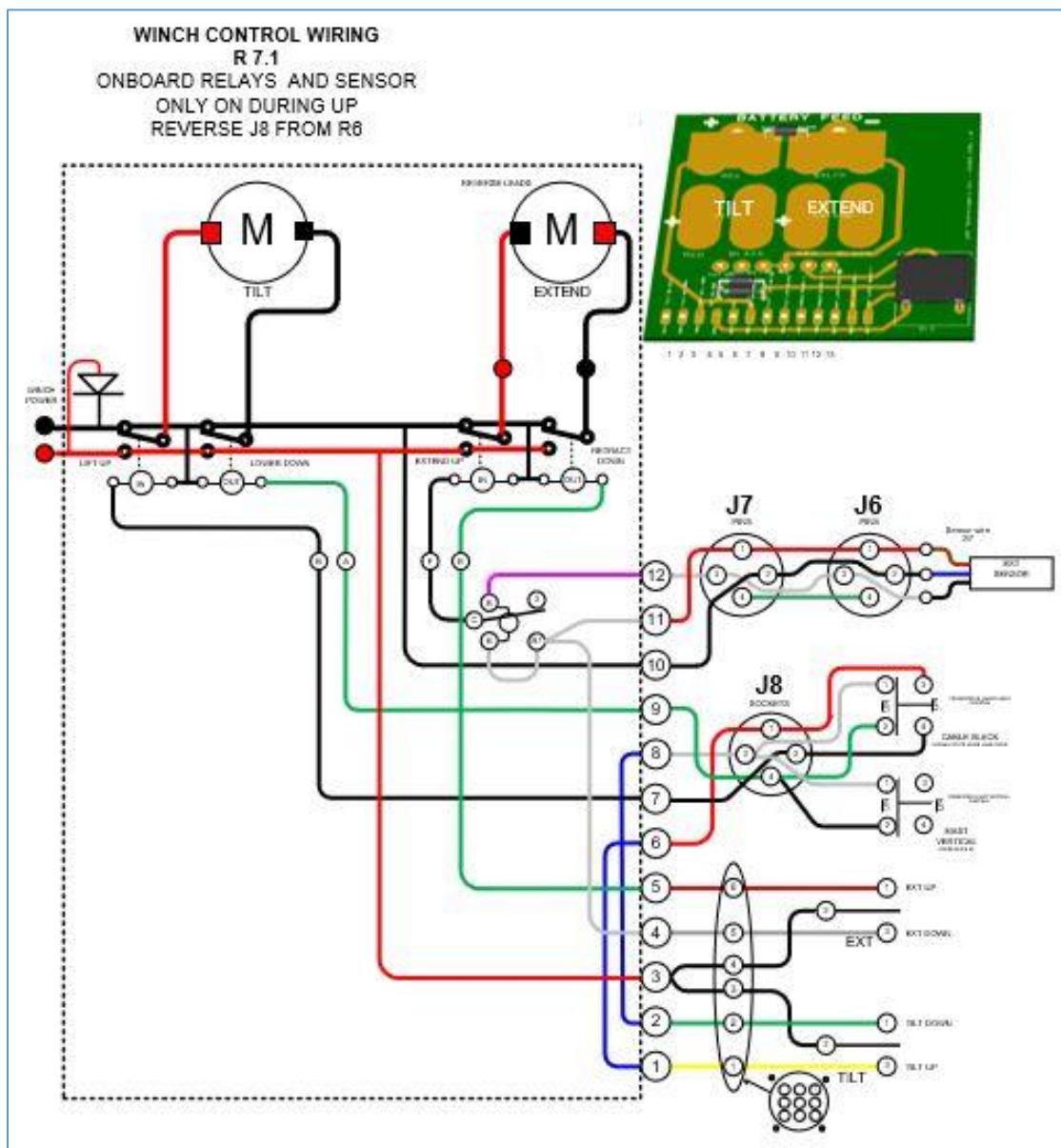

Your exact configuration may differ dependent on the products selected.

# APPENDIX A – CAMERAS AND ACCESSORIES

## I. MOUNTING POSITIONS

Find below the diagram for the mounting positions for your specific devices.

### 2 Camera System

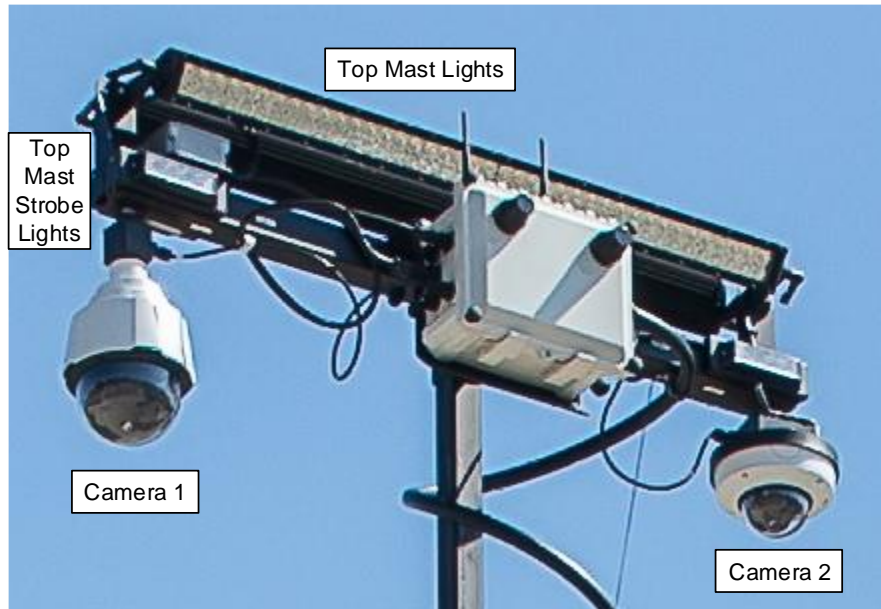

### 3 Camera System

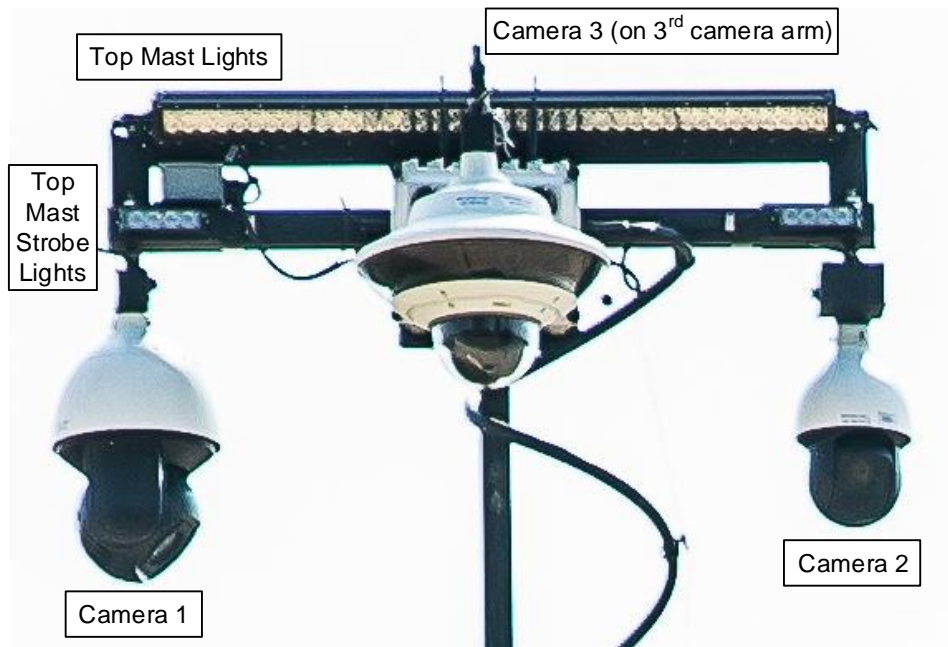

## II. ACCESSORIES

There are many accessories from Mobile Pro Systems. The following are some of the most common accessories. If your accessory is not listed and you request more information, please contact Mobile Pro Systems at 651-434-2333 for more details.

### Camera Storage Rack – (Optional)

A very common accessory is the camera storage rack. Mounted inside the trailer on the passenger side the camera storage rack has space for up to 4 cameras. Cameras should always be removed from the mast when not in use or during travel. The camera storage rack provides a convenient place for the camera to be safely stored. Remove the patch cable from the camera before placing it on the storage rack. Patch cables can be stored in the storage chest if available.

### Storage Chest – (Optional)

The optional storage chest will be located inside the main compartment of the trailer on a sliding drawer. To remove the storage chest:

1. Pull the storage chest out as far as the drawer slides will allow.
2. To release the storage chest from the drawer, remove the pins in the front and rear of the storage chest. The storage chest should then lift out.

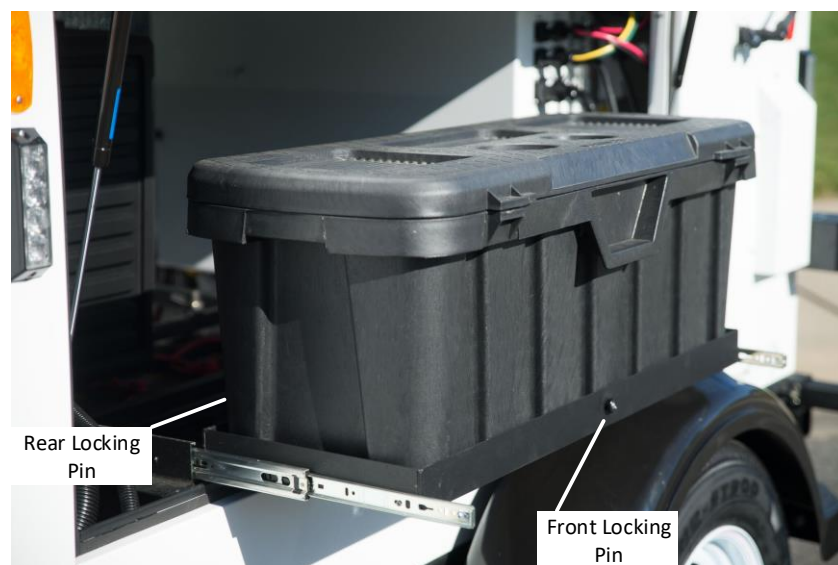

### Top Mast Strobe Lights – (Optional)

These high energy LED strobe lights can be several different colors. Law Enforcement requires RED / BLUE OR BLUE / BLUE. There is also YELLOW / BLUE, WHITE / WHITE, AND WHITE YELLOW for general use. The Top Mast Strobes should be connected to CTRL 1 on the top mast box. When properly connected the Top Mast Strobe Lights are controlled from the PCM. The Top Mast Strobe Lights uses button 1 on the 5 Button Panel. Refer to the General Operation section for button usage. They can also be controlled remotely or if motion is detected if this option was included in your package. On new trailers this accessory will already be attached. If this accessory is added at a later date, installation instructions will accompany the product.

## Top Mast Lights – (Optional)

A standard configuration has 2 – 42” long fully weatherproof LED light bars. Top Mast Light Bars should have two connection points on the top mast box. The first connection is CTRL 3 and the second is PWR 4. When properly connected, the Top Mast Light Bar can be controlled from the PCM. The Top Mast Light Bar uses button 2 on the 5 Button Panel. Refer to the General Operation section for button usage. They can also be controlled remotely if this option was included in your package. On new trailers this accessory will already be attached. If this accessory is added at a later date, installation instructions will accompany the product.

## Mid Mast PIR Kit – (Optional)

Motion detection can be used to activate lighting, send real time alerts or monitoring for immediate response. The Mid Mast PIR Kit should be connected to the Mid Mast Box by two connections. The connections are CTRL 2 and PWR 3. When properly connected the Mid Mast PIR Kit is controlled from the PCM. The Mid Mast PIR kit uses button 3 on the 5 Button Panel. Refer to the General Operation section for button usage. They can also be controlled remotely if this option was included in your package. On new trailers this accessory will already be attached. If this accessory is added at a later date, installation instructions will accompany the product.



## Body Strobes – (Optional)

Body strobes act as warning lights for Law Enforcement or in emergency situations. They can also be used as a deterrent in surveillance applications. Body strobes include 6 strobe lights placed around the trailer. Two strobe lights are located on the driver side, two on the passenger side and two in the rear of the trailer. The body strobes are combined into the J2 plug that enters the PCM. The actual connection point is a 4 pin Molex located in the trailer in the back on the driver side. The wire should be labeled CTRL 4. When properly connected, the Body Strobes are controlled from the PCM. The Body Strobes use button 4 on the 5 Button Panel. Refer to the General Operation section for button usage. They can also be controlled remotely or if motion is detected if this option was included in your package. On new trailers this accessory will already be attached. If this accessory is added at a later date, installation instructions will accompany the product.

## Speaker – (Optional)

When purchased, the speaker is typically mounted on the winch box. Speaker is used to make live, manually triggered, or automated prerecorded announcements to people on site. Two options are available; the first option is to announce only and the other allows 2-way audio. The speaker will be connected to the mid mast box to the port labeled SPKR. Once connected the speaker can be controlled from the rack mount enclosure.



## 3<sup>rd</sup> Camera Arm – (Optional)

The 3<sup>rd</sup> Camera Arm allows the trailer to be equipped with up to 3 top mast cameras. These cameras will connect to ETH 1 – ETH 3. The camera on the 3<sup>rd</sup> camera arm should connect to ETH 3. To mount a camera to the 3<sup>rd</sup> camera arm, remove the pin. Rotate part of the camera arm down to a lower height. Attach a camera using a Mobile Pro Systems camera mount similar to the T-bar. Connect the camera to ETH 3. Rotate the camera arm back up and replace the pin.

## Top Mast H bracket – (Optional)

The Top Mast H bracket is an accessory designed to attach to the T-Bar and give the user more camera mounting locations. Using the Top Mast H Bracket allows the trailer to be equipped with up to 4 top mast cameras. These cameras will connect to ETH 1 – ETH 4. One typical application of this accessory is for mounting 2 180-degree camera back to back giving the equivalent of 360-degree vision.

## Shore Power enclosure – (Optional)

Shore power enclosure provides a housing around the shore power plug. This lockable device limits the access to the shore power plug. If the trailer at any time runs off-shore power this will help protect against undesired and unintentional disconnections. Lifting the lid on the enclosure you will find a 2-pronged section. Place the electrical cord between the prongs and plug into the trailer. Next close the lid on the enclosure and locate the hole on the right side. Place a lock through this hole and the enclosure will remain shut to unauthorized personnel.



### III. IP CAMERAS

*(Your camera selections may differ from those shown below)*

Axis

<https://www.axis.com/us/en>

Hikvision

<http://www.hikvision.com/us/index.html>

Dahua

<http://www.dahuasecurity.com/en/us/>

### IV. EXACQVISION VIDEO MANAGEMENT SOFTWARE

*(Your video management software selection may differ)*

User Manuals, Spec Sheets, Quick Start Guides

<https://exacq.com/support/manspecs/>

### V. NETWORK AND CELLULAR DEVICES

*(Your network and cellular devices selection may differ)*

Cradlepoint IBR600 Integrated broadband router Quick Start Guide

<https://customer.cradlepoint.com/s/article/COR-IBR600C-Series-Quick-Start-Guide>

Cradlepoint IBR600 Integrated broadband router Manual

<https://cradlepoint.com/products/cor-ibr600-series#!resources>

## APPENDIX B – GENERATORS

### FUELING

The fuel tank capacity of the MPS-3400 is 20 US gallons. Do not overfill the fuel tanks! Trailers with black caps are for unleaded fuel and Green caps are for diesel fuel.

- A. Cummins Onan 4000 KY unleaded gas generator.
  - Use regular un-leaded fuel ONLY.

B. Power Tech PT-3SV2 diesel generator.

- Use Diesel fuel ONLY.
  - Use #1 Diesel below 30°F
  - Use #2 Diesel above 30°F

If the fuel is over-filled, you may smell and see small amounts of fuel dripping from the fuel vapor canister vent hose that exists from each fuel pod through the floor.

## CUMMINS ONAN 4000 KY

Gas Generator <https://www.cummins.com/rv-generator-manuals>

### Powering on the Unleaded Gas Generator (Manual)

Ensure that the system is powered on and the Generator Operation switch is switched to AUTO (the center position) before attempting to manually start the generator.

1. Switch the Generator Operation switch to AUTO (the center position).
2. Remove the front generator cover by turning the two cover latches counter-clockwise and pulling the cover outwards.
3. Locate the generator power control switch positioned on the lower front center of the generator. (shown in the image)
4. Prime the generator engine by pressing and holding down the left side of the generator power control switch, labeled STOP/PRIME.
5. **When the generator is OFF**, press and hold down the right side of the generator power control switch, labeled START to crank and start the generator. The red LED light will blink rapidly during cranking and will remain solid while running. Hold down the start button continuously until the engine is running to avoid flooding of the system.
6. If the generator shuts down abnormally, the red LED will blink a fault code to indicate why the system shutdown.
7. To stop the generator engine **while the generator is RUNNING**, press the left side of the generator power control switch, labeled STOP/PRIME. The engine should immediately stop running.

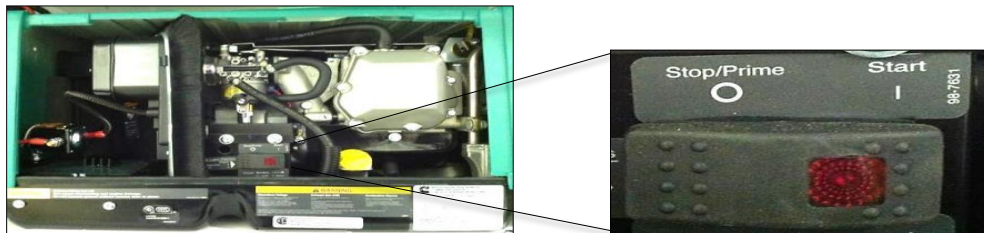

## Maintenance Procedure

MAINTENANCE PROCEDURE	MAINTENANCE FREQUENCY					
	Every Day or Every 8 Hours	After First 20 Hours	Every Month	Every 50 Hours	Every 150 Hours	Every 450 Hours
General Inspection	X					
Check Engine Oil Level	X					
Clean and Check Battery			X <sup>3</sup>			
Clean Spark Arrester				X		
Change Engine Oil		X <sup>1</sup>			X <sup>2, 3, 4</sup>	
Replace Air Filter Element					X <sup>2</sup>	
Replace Spark Plug(s)						X <sup>5</sup>
Replace Fuel Filter						X <sup>5, 6</sup>
Adjust Valve Lash						X <sup>6</sup>
1- As a part of engine break-in, change the engine oil after the first 20 hours of operation. 2- Perform more often when operating in dusty environments. 3- Perform more often when operating in hot weather. 4- Perform at least once a year. 5- Perform sooner if engine performance deteriorates. 6- Must be performed by a qualified mechanic (authorized Cummins Onan Service Representative).						

## Remedies for a Non-Responsive Generator

Consult the provided Operator Manual for the Cummins Onan 4000 KY series for other remedies.

## POWER TECH PT-3SV2

Diesel Generator <https://www.powertechgenerators.com/>

### Powering on the Diesel Generator (Manual)

Ensure that the system is powered on and the Generator Operation switch is switched to AUTO (the center position) before attempting to manually start the generator.

1. Switch the Generator Operation switch on the PCM to AUTO (the center position).
2. Remove the front generator cover and locate the generator power control switch positioned on the front right of the generator.
3. Make sure the Generator Main / ECU Reset Switch must be in the on position.
4. **When the generator is OFF**, hold the Start/Stop Switch for 1 second and release.
5. Glow Plugs will preheat for 8 seconds. The LED will flash slowly.
6. The engine will then begin an 8 second crank cycle. The system will check if there is an AC signal from the generator. If the system sees a signal the engine will start, and the LED will remain on. If the system does not see a signal a fault code will be shown.

Fault Codes:

Failure to start  
 Engine High Water Temperature  
 Low Oil Pressure  
 No AC Signal

LED Flashes

1  
 2  
 3  
 4

7. To stop the generator engine **while the generator is RUNNING**, hold the Start/Stop Switch for 1 second and release. If fault occurs turn Generator Main / ECU Reset Switch off and then on to reset the system.

## Maintenance Procedure

<b>MAINTENANCE SCHEDULE</b>						
Maintenance Service Item	See notes	Daily	100 Hours	500 Hours	1000 Hours	Remarks
Check Engine Oil Level		◆				
Check Coolant Level		◆				
Check for Oil, Fuel, and Oil Leaks		◆				
Check Electrical Connections		◆				
Check Fuel Level		◆				
Check for Water in Fuel	◆	◆				
Check Fuel Filter Element for Damage or Contaminants			◆			
Change Engine Oil and Clean Filter Screen	◆		◆			At Least Every Year
Check Engine & Generator Mounts				◆		At Least Every Year
Replace Primary Fuel Filter	◆			◆		At Least Every Year
Replace In-Line Fuel Filter (if equipped)	◆			◆		At Least Every Year
Replace Air Filter Element	◆		◆			At Least Every Year
Replace Belts					◆	At Least Every Two Years
Change Coolant					◆	At Least Every Year
Replace Fuel Lines & Hoses					◆	At Least Every Two Years
Replace Coolant Hoses and Clamps					◆	At Least Every Year

**Notes:**

1. Engine Oil must be changed after the first 50 hours of service then in 100 hour intervals after the first 50 hours.
2. Filter replacement intervals may vary depending on the quality of air, fuel, etc. These service intervals are maximums and should be adjusted based on the operating conditions of the generator set.

Maintenance Schedule (above) sourced from Power Tech Operators Manual

## Remedies for a Non-Responsive Generator

For non-responsive generators please consult the provided Power Tech Generator Operator Manual.

# APPENDIX C – SOLAR OPTIONS

## 600W SOLAR 2 PANEL SYSTEM

The standard solar system consists of 2-300W solar panels. These solar panels are permanently mounted to the top of the trailer enclosure and no attempt should be made to remove them. The energy absorbed from the sun is transmitted into the trailer and inside the PCM. Once inside the PCM it is directed through the solar charge controller. From the controller the energy is either used to recharge the batteries or for standard operation. There are two modes for this solar system the first one is the travel mode and the second is deployed mode. The solar system should be in travel mode when the system is being moved or not in use.

To deploy the solar panels from travel mode:

1. First remove the pin holding the solar panels to the trailer. This pin is located in the middle of the trailer on the passenger side.
2. Next, the top panel is folded off the lower panel and locked in place by moving the slide rods located on each side of the top panel into the lower panel. To move the slides, loosen the black knobs sand slide into position. They should then be secured by tightening the black knobs. Both panels should create one uniformed flat surface.
3. Secured panels are then ready to be tilted into position. This is done by lifting the lower panel off the trailer top and then pulling down the angle support brackets.
4. These brackets should then be secured by matching the holes on the brackets with the holes on the solar panel frame. Inserting the locking pins attached to the solar bracket by a small chain will secure the position of the panels.
5. Check to make sure the cable coming from the solar panels is connected to the trailer. This connection point is on the driver's side near the rear.



To return the solar panels to travel mode:

1. Release the locking pins on the support brackets.
2. Fold the support brackets underneath the solar panels and tilt the solar panels so they lay flat on the roof.

3. Retract both of the slide rods on either end of the trailer and lock them in place.
4. Then flip the outside panel on to the trailer.
5. Lastly place the travel pin back into the passenger side of the solar panels and through the trailer.
6. Make sure the locking pins for the support bracket are returned to their holes for safe keeping.

## 900W SOLAR 3 PANEL SYSTEM

This solar system consists of 3-300W solar panels. These solar panels are permanently mounted to the top of the trailer enclosure and no attempt should be made to remove them. The energy absorbed from the sun is transmitted into the trailer and inside the PCM. Once inside the PCM it is directed through the solar charge controller. From the controller the energy is either used to recharge the batteries or for standard operation. There are two modes for this solar system the first one is the travel mode and the second is deployed mode. The solar system should be in travel mode when the system is being moved or not in use.

To deploy the solar panels from travel mode:

1. Loosen the black knobs on the top panel on the trailer and remove the small angle brackets one from each side of the solar panels. Retighten the black knobs.
2. Fold off the top panel and move the slide rods into the lower panel. They slide rods can be moved by loosening the black knobs. Once in the correct position retighten the knobs.
3. Next unfold the middle panel and secure the same way as the top panel by the slide rods on either end of the trailer.
4. All 3 panels should create one uniformed flat surface. Secured panels are then ready to be tilted into position. The panels will be helped into the tilted position by the gas strut.
5. Next there is a rod along each end of the solar panels. One side of this rod has a quick release joint. Release the joint from the trailer and swing the rod so it is pointing vertical. You will then need to stand on the fender to reach the quick release side to the ball stud on the top panel. This rod is the primary support for the solar panels.
6. Repeat this step for the other side of the solar panels.
7. Check to make sure the cable coming from the solar panels is connected to the trailer. This connection point is on the driver's side near the rear.

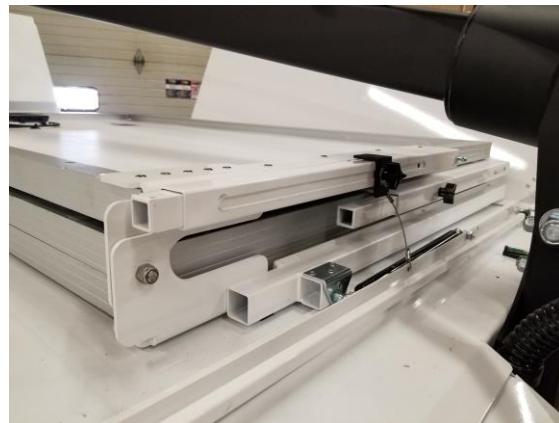

To return the solar panels to travel mode:

1. Stand on the fenders to release the quick release joints on the top panel and reattach these joints to the top of the trailer where they snap into their storage place.
2. Then tilt the solar panels to be level with the trailer.
3. The panel on the driver side of the trailer must be stowed first. Stow this panel by loosening the black knobs on either end of the trailer and sliding the slide rods back in. retighten the black knobs and flip the solar panel back onto the top of the trailer.
4. Next release the slide rods on the other solar panel and slide them back into their holders and retighten the black knobs. Then flip the solar panel back on to the top of the trailer.
5. To secure the panels for travel loosen the black knobs on the top panel and place the hold down brackets over the knobs as shown and tighten down the knobs. Make sure both mounting brackets one on either end of the trailer are locked into position.

**For technical QUESTIONS, please contact Mobile Pro Systems Customer Support or Technical Support team at 651-434-2333 or [Support@mobileprosystems.com](mailto:Support@mobileprosystems.com) Please have your system serial number available during the call.**